



NEOS TECHNOLOGIES

A Gooch & Housego Company

OPERATING MANUAL

**SIX NANOSECOND AOM /
PULSE PICKER**

MODEL NUMBERS:

17389-.93

DOCUMENT NUMBER: 51A14832

Document approved for release: W Seale Date: 6/16/06

US OFFICE: NEOS Technologies, Inc. ♦ 4005 Opportunity Drive ♦ Melbourne, FL 32934 ♦ USA

Tel: (321) 242-7818 ♦ Fax: (321) 242-1019 ♦ Email: neos@neostech.com

UK OFFICE: Gooch & Housego ♦ The Old Magistrates Court ♦ Ilminster, Somerset TA19 0AB ♦ UK

Tel: +44 1460 52271 ♦ Fax: +44 1460 54972 ♦ Email: sales@goochandhousego.com

TABLE OF CONTENTS

<u>SECTION</u>	<u>DESCRIPTION</u>	<u>PAGE</u>
I.	INSPECTION PROCEDURE	3
II.	DESCRIPTION	4
III.	SPECIFICATIONS	5
IV.	OUTLINE DRAWINGS	6
V.	CALCULATIONS	7
VI.	OPERATING PROCEDURE	8
VII.	CLEANING PROCEDURE	10

SECTION I**INSPECTION PROCEDURE**

Examine the shipping carton for damage. If the shipping carton or packing material is damaged it should be kept for the carrier's inspection. Notify the carrier and NEOS Technologies. Check the contents of the shipment for completeness, mechanical damage, and then test the equipment electronically. Operating procedures are contained in Section VI. If the contents are incomplete, or the equipment does not pass the electrical testing please notify NEOS Technologies.

If there is any problem with the use of this equipment, or if the equipment fails to function as expected contact NEOS Technologies, do not try to trouble shoot or repair this equipment. Consult with a NEOS service engineer. If the equipment needs repair or replacement, contact NEOS Technologies, Inc for a Return Authorization Number.

SECTION II
DESCRIPTION

ACOUSTO-OPTIC MODULATOR /
PULSE PICKER
17389-.93

The 17389-.93 modulator consists of a Tellurium Dioxide crystal with a Lithium Niobate transducer. Optimum diffraction efficiency will be provided with a rise time of 7 ns or greater correlating to a waist diameter in the TeO₂ crystal of 35 μm. This modulator in the 17389-.93 -FOA package is available with a mount and lens assembly 71009. If the modulator assembly is purchased without the mount, then the modulator should be mounted on a fixture to provide sufficient adjustment to peak the modulator efficiency (Bragg angle, horizontal, and vertical position) and the lenses must be supplied to achieve the rise time. See section V for calculations.

The modulator can be driven with any good driver with a nominal 50 Ω output of 389 MHz, however, it is recommended that a NEOS driver be used to drive this modulator to achieve optimum performance. When the modulator is used as a pulse picker, it is recommended that the NEOS 643ZZ.ZZZ-SYN-Y-X Driver be used as it is designed to provide a RF drive signal that is synchronous to the pulse rate of the laser cavity. The 3ZZ.ZZZ in the model number of the driver is the output frequency of the driver, which is a multiple of the laser cavity resonate frequency. The “X” is a customer selectable division factor, which sets the output pulse repetition rate from the driver. The RF input to the modulator should not exceed 1 watt CW or average power. NEOS will not warranty any such damage resulting from too much RF power. Be extremely careful not to focus the laser beam on the gold bond wires on the acoustic transducer, which may vaporize the bond wires. NEOS will not warranty any such damage. The modulator has been designed and verified to satisfy the specifications.

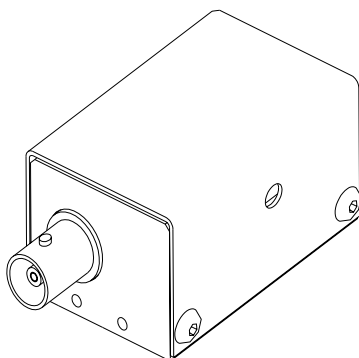

53B0504

SECTION III
SPECIFICATIONS

17389-.93

<u>PARAMETER</u>	<u>SPECIFICATION</u>
Interactive Material	TeO ₂
Acoustic Mode	Longitudinal
Operating Wavelength	700 –1064 nm
Window Configuration	AR Coated
Transmission	>95 %
Operating Frequency	389 MHz nominal
Diffraction Efficiency	>70 % @ 800 nm with Linear, Polarization Perpendicular to Acoustic Propagation. >60 % @ 800 nm with Random Polarization.
Acoustic Aperture Size	70 μm
Rise Time	< 7 ns
Extinction Ratio *	>20 dB for neighboring pulses, >27 dB for subsequent pulses @ < 80 MHz pulse rep rate
Optical Waist Size to achieve Rise Time	35 μm
Deflection Angle	73 mrad @ 800 nm
RF Power Level	< 700 mW average / 5 watts peak @ 10 % max duty cycle with 10 nsec pulse.
Impedance	50 Ω nominal
VSWR	<1.5:1 @ 389 MHz
Package	53B0504
Acceptance Test Procedure:	42A12280
Acceptance Test Results Form:	52A9461
Recommended Drivers:	
Synchronous Driver:	643ZZ.ZZZ-SYN-Y-X
Non-synchronous Driver:	11389-5AM

*When used with the 11389-5AM or 643ZZ.ZZZ-SYN-Y-X drivers

SECTION IV
OUTLINE DRAWING

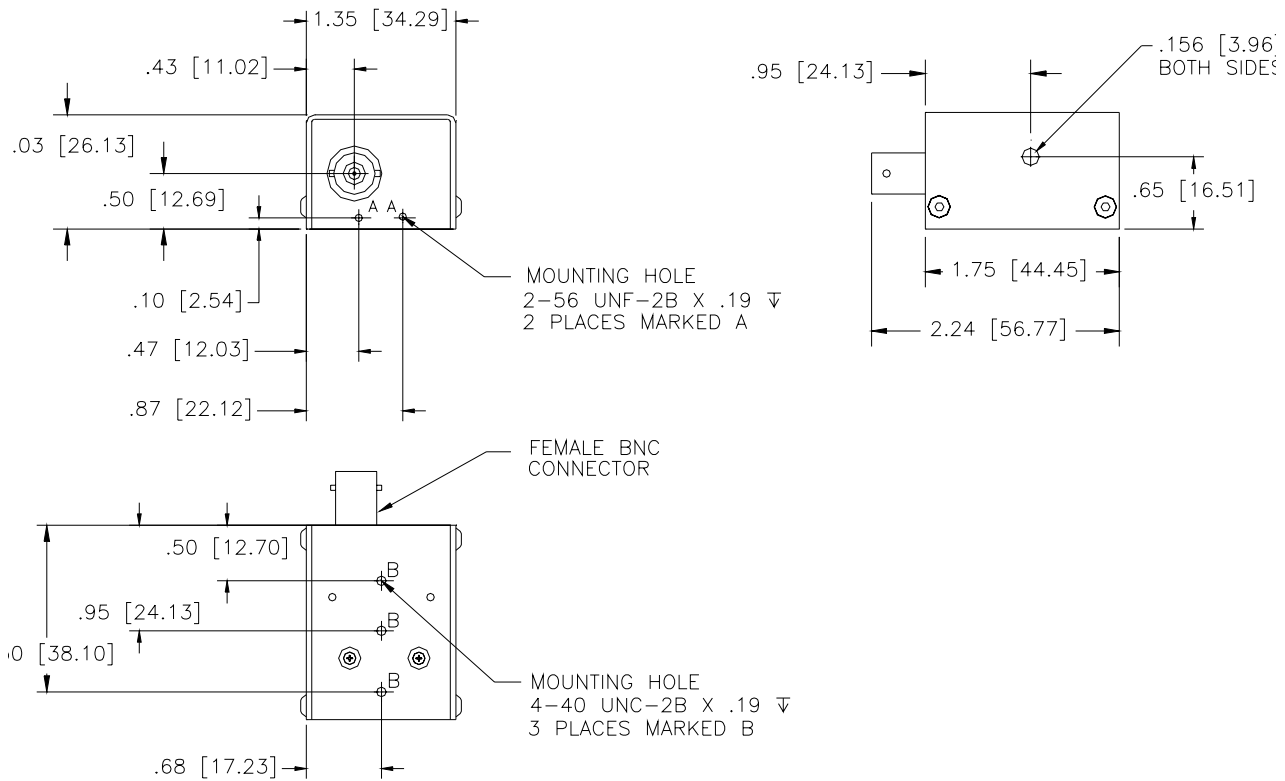

17389-93

53B0504

Dimensions are in inches

Tolerances:

Decimal: .xx = .01 .xxx = .005

Dimensions in [] are in mm.

Millimeter: .xx = .25mm .xxx = .127mm

Angle: = $\pm 30'$

SECTION V

CALCULATIONS

- The equations to determine the AOM rise time "t_r" are as follows:

First determine the waist size by the equation,
$$d_0 = \frac{4f\lambda}{\pi d_1}$$

Where: f = lens focal length in mm

λ = the optical wavelength in 10^{-6} m

d₁ = the input optical beam diameter in mm

d₀ = the waist diameter inside the modulator in 10^{-6} m

Knowing the waist size inside the modulator, then the modulator rise time can be calculated from the relationship:

$$t_r = \frac{1.3d_0}{2V}$$

Where: V = the acoustic velocity of the modulator material which is 4260 m/s

- The focal length of the lens is the F# of the lens times the input spot diameter:

$$F\# d_1 = f_{\text{lens}}$$

- The deflection angle " \varnothing_d " is defined as the acoustic drive frequency in megahertz times the wavelength, divided by the acoustic velocity of the material:

$$\varnothing_d = 2\theta_{\text{Bragg}} = \frac{f_a \lambda}{V} = \frac{389 * \lambda}{4260 \text{ m/s}}$$

Where: θ_{Bragg} = Bragg angle of the modulator.

* 389 MHz nominal. The frequency should be a multiple of the laser cavity resonate frequency.

SECTION VI.**OPERATING PROCEDURE**

Mount the modulator in the optical path with the laser beam passing through the device window centered on the window vertically and close to the transducer (connector side). The modulator is polarization sensitive and performs best with light linear polarized, oriented perpendicular to the acoustic propagation axis. Random polarization can be used but the diffraction efficiency will be reduced by 10 %. The modulator mount assembly must have sufficient adjustments to peak the modulator efficiency (horizontal, vertical, and Bragg angle). Be extremely careful not to focus the laser beam on the gold bond wires on the acoustic transducer, which may vaporize the bond wires. NEOS will not warranty any such damage.

Using a 50 Ω coaxial cable, connect the "RF out" of the driver to the modulator. Turn on the RF power. Be sure the mode switch is in the CW position on the NEOS driver system. Make sure that the RF power does not exceed 1 watt CW. NEOS will not warranty any failure resulting from the application of too much RF power.

With the laser beam going through the optical crystal, and close to the transducer, adjust the Bragg angle, by rotating the AOM, to allow the diffracted first order beam away from the transducer (connector end) to be the most intense. See figure 3

Install the lens, as calculated above, into the laser beam on the input side of the modulator to achieve the desired rise time. Position the lens 1 "f" away from the modulator and adjust the height of the modulator to achieve diffraction. Make changes in the Bragg adjustment screw to obtain optimum efficiency. Install a second lens 1 "f" away from the modulator on the output side to re-collimate the output beam. Make changes in the Bragg adjustment and height to obtain optimum efficiency. Adjust the RF driver for power level to obtain maximum diffraction efficiency.

For optimum results, the Bragg angle must be precisely adjusted. The angle between the diffracted and the zero order beam is approximately equal to 0.076 radians with a wavelength of 0.93 micrometers.

When the modulator is used for pulse picking, and if using the NEOS 643ZZ.ZZZ-SYN-Y-X driver, then set the driver to pulse mode. Set the driver to output RF pulses at the desired pulse rate. Do not exceed 5 watts peak RF power, @ 10 % duty cycle with a 10 ns width pulse. Do not exceed 1 watt average power. Do not adjust the pulse rate of the driver with the modulator connected to the driver.

Adjust the phase of the RF and the time delay to select the desired laser pulse from the laser pulse train. The position of the laser beam in the modulator (distance from the transducer) also will affect the time delay. See the driver manual for other information on required sync signal, setup instructions, and warnings. The modulator has been designed and verified to satisfy the specifications before shipment.

Figure 3

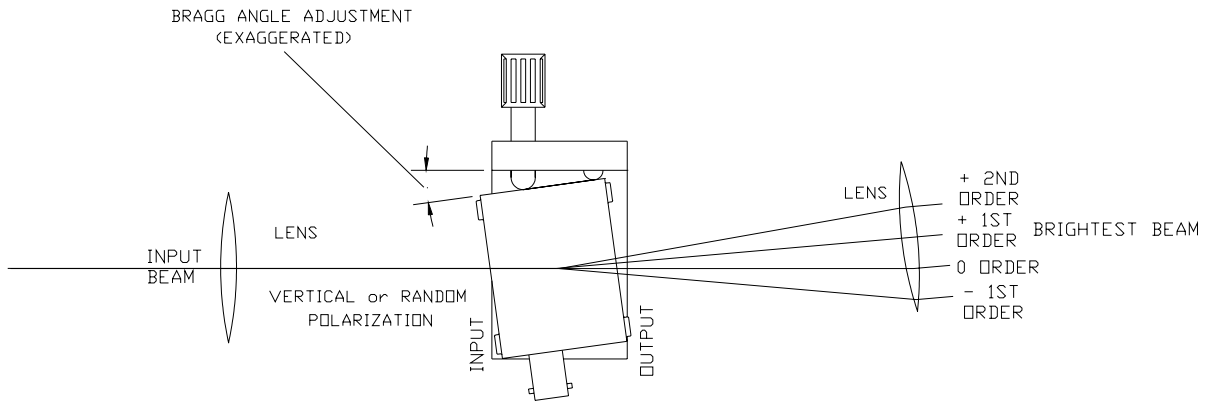

AOM Bragg Adjustment

SECTION VII**OPTICAL CLEANING**

Periodic cleaning of the AO device is a normal part of maintaining an optical system. When the device is installed in an optical system, make sure that there is access to allow removal of the protective cover and room to clean the device. If removal from the system is necessary, then follow the alignment procedure in this manual to reinstall, realign and, adjust the AO device.

To clean the AO device, remove the screws that hold the cover to the mount. **Caution** must be used when placing a screw driver near the window opening in the cover, as it is best to protect the opening with tape or cover the opening with your finger (without touching the crystal) to protect it. NEOS will not warrant any damage or scratches caused by inserting the screwdriver into the window opening.

- Remove the protective cover.
- Blow off any visible dust with canned air. Do not use an air gun unless it is filtered and water and oil free!
- Fold (4 times) a new lens tissue into a triangle to make a cleaning tool.
- Dip the tip of the lens tissue into **fresh** acetone or spray **fresh** acetone from a squeeze bottle onto it. Then shake excess fluid out of the lens tissue. Do not handle the wet area of the tissue, as your finger oil will be absorbed and contaminate the optical surface of the crystal.
- Wipe (only once) across the crystal in an even motion, starting near the transducer and drawing the tissue across the optical surface toward the other end. Do not damage the bond wires! Do not reuse the tissue as the mounting silver epoxy may be spread onto the window of the crystal.
- Repeat with a new tissue each time and for each surface that needs cleaning.
- Replace the protective cover and screws.
- Realign the device in your system and adjust the Bragg angle for maximum diffraction efficiency.

Notes:

- The lens tissue must be lint free and the best grade available.
- Only use each tissue once, for only one surface. Do not reuse the tissue, as it will redistribute the removed dust or mounting silver epoxy.
- The acetone must be electronic grade. The acetone **must** be **fresh** from a **new** bottle, as the acetone will absorb water from the air and cause streaks. Discard any acetone, which has been exposed to the air for more than 4 hours. If the bottle is half- empty, do not use.