

# NEOS TECHNOLOGIES

A Gooch & Housego Company

MODEL NUMBER:

## 64048-80-.1-8CH-16

### SPECIFICATIONS

DOCUMENT NUMBER: 56A15627A

#### Product Description:

The 64048-80-.1-8CH-16 is an eight channel, frequency synthesized driver for the **48058** series Poly-Chromatic Acousto Optic Modulator (PCAOM) which can modulate eight wavelengths of light at the same time. The driver has analog modulation and TTL blanking for each channel. The wavelengths for each channel are switch selectable from 16 standard wavelengths stored in an E-Prom (see page 4 lookup table). Other wavelengths can be custom factory programmed.

#### PARAMETER

#### SPECIFICATION

Number of Channels	Eight
Frequency Stability	$\pm .01\%$
Power Out	50-200 mW / Channel
Wavelengths per Channel	16
Fine Tuning Range	+ 56 KHz, - 64 KHz in 8 KHz Steps
Analog Inputs (8)	0-5 Volts into 10K Ohms
Blanking Inputs (8)	TTL, 4.7K Ohms pull ups. No input or high is not blanked.
Rise/Fall Time	500 ns Max
Extinction Ratio	Analog > 60dB TTL > 60dB
Power	100-240 VAC, 50-60Hz, 1.5A Maximum
Connectors:	
RF out	BNC Female mates with Amphenol P/N 69475
Data in	25 Pin D-Sub Female mates with Panduit P/N IDM25PH5
TP1 (-20dB)	SMB Male mates with ITT Cannon P/N B51-007-0000-220
Outline Drawing:	53D3423



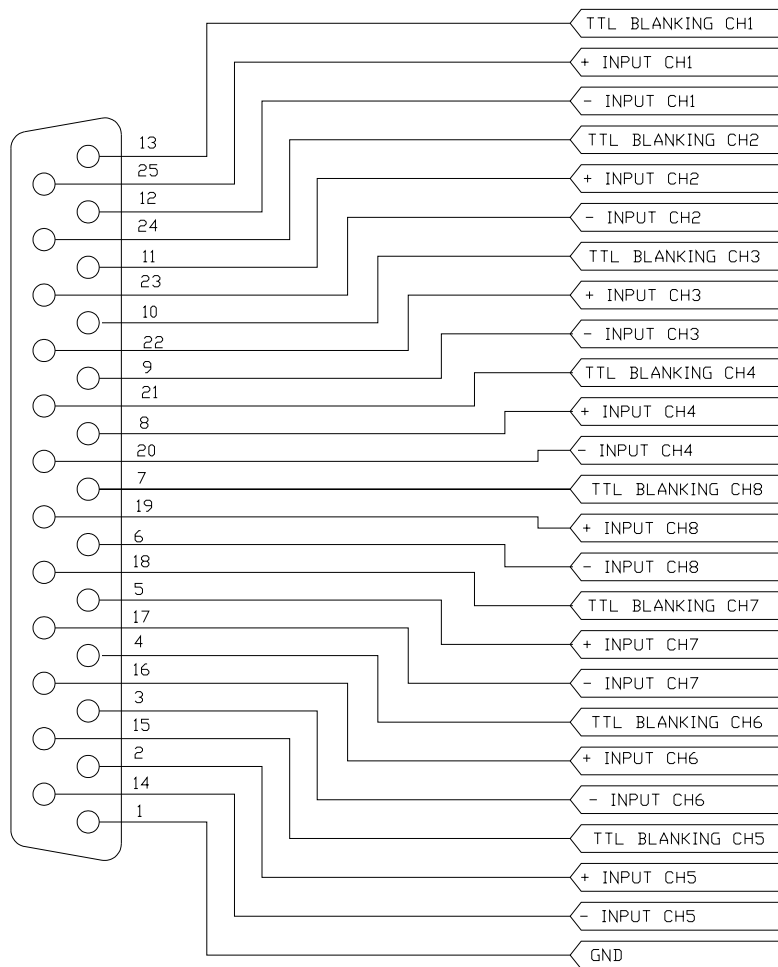

FIGURE 3  
 J1 PINOUT  
 FEMALE DB25  
 8CH-16 DRIVER

45A8212A

**SWITCH SETTINGS VS. WAVELENGTH FOR EACH CHANNEL**  
**STANDARD WAVELENGTHS LOOKUP TABLE**

SWITCH POSITION	WAVELENGTH nm
0	676
1	647
2	632
3	575
4	568
5	530
6	528
7	520
8	514
9	501
A	496
B	488
C	476
D	472
E	465
F	457