



NEOS TECHNOLOGIES

A Gooch & Housego Company

OPERATING MANUAL

**55 MHz ACOUSTO OPTIC MODULATOR
FOR 1064-2100 nm**

MODEL NUMBER:

26055-1-1.55-LTD

DOCUMENT NUMBER: 51A18835

Document approved for release: W Seale Date: 6/26/06

US OFFICE: NEOS Technologies, Inc. ♦ 4005 Opportunity Drive ♦ Melbourne, FL 32934 ♦ USA

Tel: (321) 242-7818 ♦ Fax: (321) 242-1019 ♦ Email: neos@neostech.com

UK OFFICE: Gooch & Housego ♦ The Old Magistrates Court ♦ Ilminster, Somerset TA19 0AB ♦ UK

Tel: +44 1460 52271 ♦ Fax: +44 1460 54972 ♦ Email: sales@goochandhousego.com

TABLE OF CONTENTS

| SECTION | DESCRIPTION | PAGE |
|----------------|------------------------|-------------|
| I. | INSPECTION PROCEDURE | 3 |
| II. | DESCRIPTION | 4 |
| III. | SPECIFICATIONS | 5 |
| IV. | OUTLINE DRAWING | 6 |
| V. | CALCULATIONS | 7 |
| VI. | OPERATING INSTRUCTIONS | 8 |
| VII. | CLEANING INSTRUCTIONS | 10 |

SECTION I
INSPECTION PROCEDURE

Examine the shipping carton for damage. If the shipping carton or packing material is damaged it should be kept for the carrier's inspection. Notify the carrier and NEOS Technologies. Check the contents of the shipment for completeness, mechanical damage, and then test the equipment electronically. Operating procedures are contained in Section VII. If the contents are incomplete, or the equipment does not pass the electrical testing please notify NEOS Technologies.

If there is any problem with the use of this equipment, or if the equipment fails to function as expected contact NEOS Technologies, do not try to trouble shoot or repair this equipment. Consult with a NEOS service engineer. If the equipment needs repair or replacement, contact NEOS Technologies, Inc for a Return Authorization Number.

SECTION II
DESCRIPTION
26055-1-1.55-LTD

The 26055-1-1.55-LTD modulator consists of an AMTIR ($\text{Ge}_{33}\text{Se}_{55}\text{As}_{12}$) substrate with a Lithium Niobate transducer and is designed to be used for wavelengths between 1 and 2 μm . The input laser beam diameter can be varied to produce the desired rise time needed, which can be as much as 260 nanoseconds with a 1 mm beam diameter. The maximum optical power density should not exceed 50 KW/cm^2 . The modulator assembly should be mounted on a fixture to provide sufficient adjustment to peak the modulator efficiency (Bragg angle, horizontal, and vertical position) and the lenses must be supplied to achieve the rise time. See section V for calculations.

The modulator can be driven by any good driver with a nominal 50 ohm output @ 55 MHz, however, it is recommended that a NEOS driver be used to drive this modulator for the system to achieve optimum performance. The RF input should not exceed 1.0 watt CW. Be extremely careful not to focus the laser beam on the gold bond wires. NEOS will not warranty any such damage. The modulator has been designed and verified to satisfy the specifications.

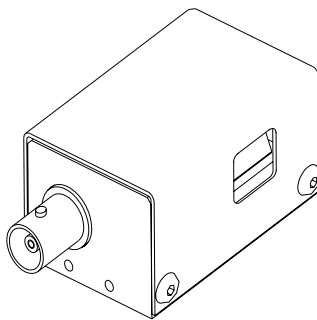

SECTION III
SPECIFICATIONS

26055-1-1.55-LTD

| <u>PARAMETER</u> | <u>SPECIFICATION</u> |
|---------------------------------|---|
| Interactive Material | AMTIR |
| Acoustic Mode | Longitudinal |
| Operating Wavelength | 1064-2100 nm |
| Window Configuration | AR Coated |
| Static Transmission | >95 % @ 1064 nm * >97% @ 1550 nm >90% @ 2100 nm * |
| Operating Frequency | 55.00 MHz |
| Diffraction Efficiency | 85 % @ 1064 nm 85 % @ 1550 nm 55 % @ 2100 nm |
| Light Polarization | Random |
| Optical Power Density: | < 50 KW/cm ² |
| Acoustic Aperture Size | 1 mm |
| Rise Time | 260 ns / mm Beam Diameter |
| Deflection Angle | 23.3 mrad @ 1064 nm 32.4 mrad @ 1550 nm 46.0 mrad @ 2100 nm |
| RF Power Level | <1 Watt |
| Impedance | 50 Ohms |
| VSWR | 1.2:1 @ 27.12 MHz |
| Package: | 53D0624 TO1 |
| Acceptance Test Procedure: | 42A12285 |
| Acceptance Test Results form: | 52A02488 |
| Recommended Drivers: | |
| Analog Driver System: 21055-1AS | Digital Driver System: 21055-1DS |
| Analog Driver Module: 21055-1AM | Digital Driver Module: 21055-1DM |

SECTION IV
OUTLINE DRAWING

53D0624 TO1

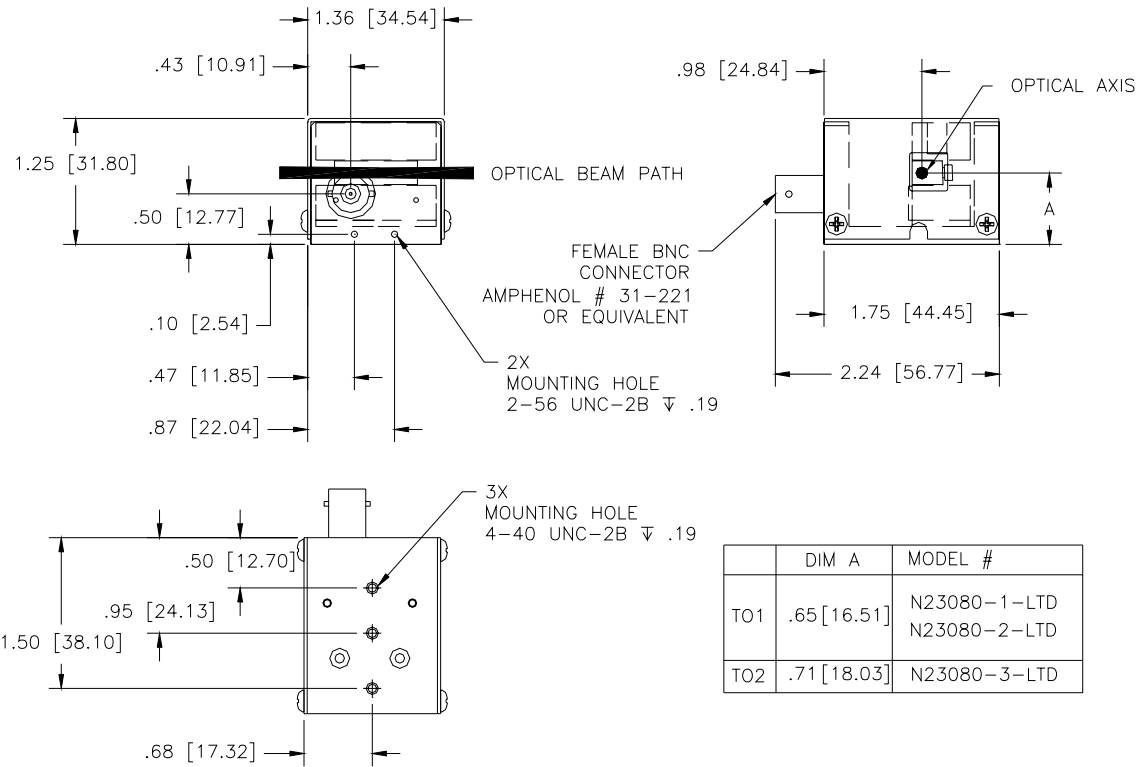

| | DIM A | MODEL # |
|-----|-------------|------------------------------|
| TO1 | .65 [16.51] | N23080-1-LTD N23080-2-LTD |
| TO2 | .71 [18.03] | N23080-3-LTD |

Dimensions are in inches

Tolerances:

Decimal: .xx = .01 .xxx = .005

Dimensions in [] are in mm.

Millimeter: .xx = .25mm .xxx = .127mm

Angle: = ± 30'

SECTION V

CALCULATIONS

- The equations to determine the AOM rise time "t_r" are as follows:

First determine the waist size by the equation, $d_0 = \frac{4f\lambda}{\pi d_1}$

Where: f = lens focal length in mm

λ = the optical wavelength in 10^{-6} m

d₁= the input optical beam diameter in mm

d₀= the waist diameter inside the modulator in 10^{-6} m

Knowing the waist size inside the modulator, then the modulator rise time can be calculated from the relationship:

$$t_r = \frac{1.3d_0}{2V}$$

Where: V = the acoustic velocity of the modulator material which is 2510 m/s

- The focal length of the lens is the F# of the lens times the input spot diameter:

$$F\# d_1 = f_{lens}$$

- The deflection angle " \varnothing_d " is defined as the acoustic drive frequency in megahertz times the wavelength, divided by the acoustic velocity of the material:

$$\varnothing_d = 2\theta_{Bragg} = \frac{f_a \lambda}{V} = \frac{55.00 \times 10^6 \lambda}{2510 \text{ m/s}}$$

Where: θ_{Bragg} = Bragg angle of the modulator.

SECTION IV. OPERATING INSTRUCTIONS

Use an IR viewer or a IR card to view the laser light.

The modulator device is not polarization sensitive, so any optical polarization can be used. Be extremely careful not to focus the laser beam on the gold bond wires on the acoustic transducer, which may vaporize the bond wires. NEOS will not warranty any such damage. The modulator mount assembly should have sufficient adjustments to peak the modulator efficiency (Bragg angle, horizontal, and vertical position) and the lenses must be supplied to achieve the rise time. For optimum results, the Bragg angle must be precisely adjusted.

If using a NEOS driver, set the mode switch is in the CW position. Make sure that the RF power does not exceed 1 watt @ 55 MHz. NEOS will not warranty any failure resulting from the application of too much RF power. Using a 50 ohm coaxial cable, connect the "RF out" of the driver to the modulator. Turn on the RF power.

Direct a laser beam onto the optical crystal, with the optical beam close to the transducer. View the output beams on a surface one meter away using an IR viewer. Adjust the Bragg angle, by rotating the AOM, to allow the diffracted first order beam away from the transducer (connector end) to be the most intense. See figure 3.

Install the input lens, one "f" away, and adjust the height of the modulator to achieve diffraction. Make changes in the Bragg adjustment to obtain optimum efficiency. Adjust the RF driver for power level to obtain maximum diffraction efficiency. Install the output lens, one "f" away, to collimate the output beam.

To operate the modulator use the first order diffracted beam with the NEOS driver mode switch set to normal. See the driver manual for information on signal needed for modulation.

Figure 3

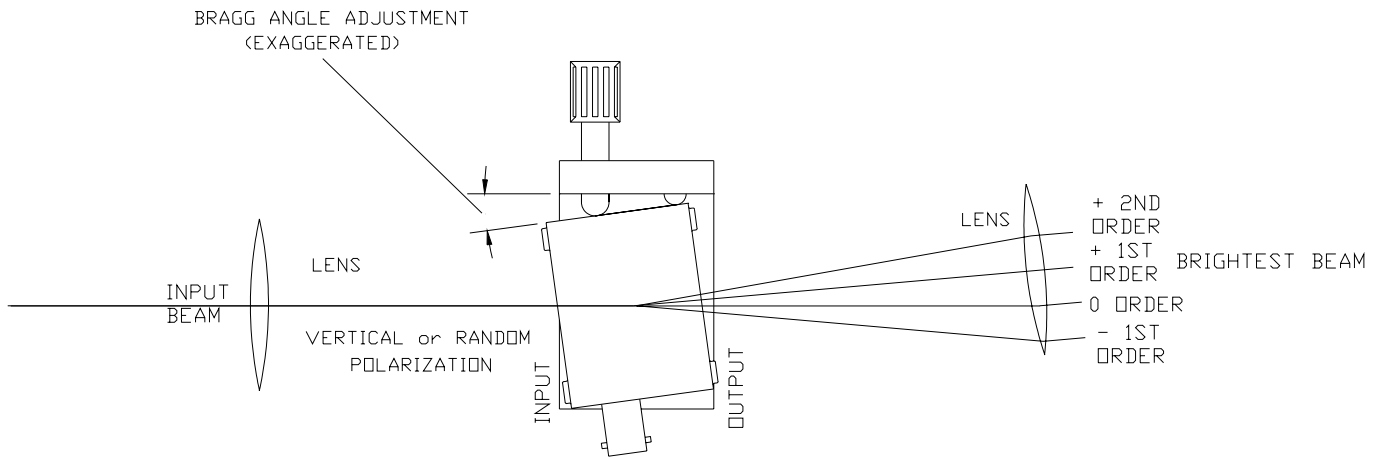

AOM BRAGG ADJ.

SECTION VII**OPTICAL CLEANING**

Periodic cleaning of the AO device is a normal part of maintaining an optical system. When the device is installed in an optical system, make sure that there is access to allow removal of the protective cover and room to clean the device. If removal from the system is necessary, then follow the alignment procedure in this manual to reinstall, realign and, adjust the AO device.

To clean the AO device, remove the screws that hold the cover to the mount. Caution must be used when placing a screw driver near the window opening in the cover, as it is best to protect the opening with tape or cover the opening with your finger (without touching the crystal) to protect it. NEOS will not warrant any damage or scratches caused by inserting the screwdriver into the window opening.

- Remove the protective cover.
- Blow off any visible dust with canned air. Do not use an air gun unless it is filtered and water and oil free!
- Fold (4 times) a new lens tissue into a triangle to make a cleaning tool.
- Dip the tip of the lens tissue into fresh acetone or spray fresh acetone from a squeeze bottle onto it. Then shake excess fluid out of the lens tissue. Do not handle the wet area of the tissue, as your finger oil will be absorbed and contaminate the optical surface of the crystal.
- Wipe (only once) across the crystal in an even motion, starting near the transducer and drawing the tissue across the optical surface toward the other end. Do not damage the bond wires! Do not reuse the tissue as the mounting silver epoxy may be spread onto the window of the crystal.
- Repeat with a new tissue each time and for each surface that needs cleaning.
- Replace the protective cover and screws.
- Realign the device in your system and adjust the Bragg angle for maximum diffraction efficiency.

Notes:

- The lens tissue must be lint free and the best grade available.
- Only use each tissue once, for only one surface. Do not reuse the tissue, as it will redistribute the removed dust or mounting silver epoxy.
- The acetone must be electronic grade. The acetone must be fresh from a new bottle, as the acetone will absorb water from the air and cause streaks. Discard any acetone, which has been exposed to the air for more than 4 hours. If the bottle is half- empty, do not use.