



**NEOS TECHNOLOGIES**

A Gooch & Housego Company

OPERATING MANUAL

**125 MHz CENTER FREQUENCY  
ACOUSTO-OPTIC BEAM DEFLECTOR**

MODEL NUMBER:

**45125-2/10-.355-I**

DOCUMENT NUMBER: 51A18076

Document approved for release: W Seale      Date: 5/14/05

US OFFICE: NEOS Technologies, Inc. ♦ 4005 Opportunity Drive ♦ Melbourne, FL 32934 ♦ USA

Tel: (321) 242-7818 ♦ Fax: (321) 242-1019 ♦ Email: [neos@neostech.com](mailto:neos@neostech.com)

UK OFFICE: Gooch & Housego ♦ The Old Magistrates Court ♦ Ilminster, Somerset TA19 0AB ♦ UK

Tel: +44 1460 52271 ♦ Fax: +44 1460 54972 ♦ Email: [sales@goochandhousego.com](mailto:sales@goochandhousego.com)

**TABLE OF CONTENTS**

<u>SECTION</u>	<u>DESCRIPTION</u>	<u>PAGE</u>
I.	INSPECTION PROCEDURE	3
II.	DESCRIPTION	4
III.	SPECIFICATIONS	5
IV.	OUTLINE DRAWING	6
V.	CALCULATIONS	7
VI.	OPERATING PROCEDURE	8
VII.	CLEANING PROCEDURE	10

## **SECTION I**

### **INSPECTION PROCEDURE**

Examine the shipping carton for damage. If the shipping carton or packing material is damaged it should be kept for the carrier's inspection. Notify the carrier and NEOS Technologies. Check the contents of the shipment for completeness, mechanical damage, and then test the equipment electronically. Operating procedures are contained in Section VI. If the contents are incomplete, or the equipment does not pass the electrical testing please notify NEOS Technologies.

If there is any problem with the use of this equipment, or if the equipment fails to function as expected contact NEOS Technologies, do not try to trouble shoot or repair this equipment. Consult with a NEOS service engineer. If the equipment needs repair or replacement, contact NEOS Technologies, Inc for a Return Authorization Number.

## SECTION II DESCRIPTION

The 45125-2/10-.355-I acousto-optic beam deflector (AOBD) is fabricated from SiO<sub>2</sub> crystal quartz with a LiNbO<sub>3</sub> longitudinal wave transducer.

. The AOBD can be driven by any good driver with a 50-ohm nominal output; however, it is recommended that a NEOS Technologies driver be used to drive this deflector to achieve optimum performance. The RF input power should not exceed 10 Watts CW as NEOS Technologies will not warranty damage caused by applying to much RF power.

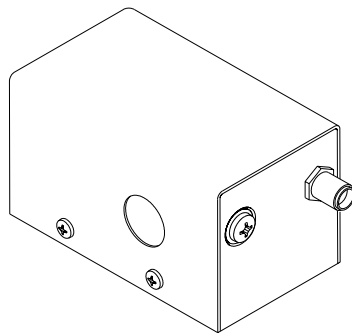

**45125-2/10-.355-I**

53B1289

**SECTION III****DEVICE SPECIFICATIONS****45125-2/10-.355-I**

<u>PARAMETER</u>	<u>SPECIFICATION</u>
Interactive Material	Crystal Quartz
Acoustic Mode	Longitudinal
Operating Wavelength	355 nm
Window Configuration	AR Coated
Static Transmission	>97 %
Operating Frequency	100 to 150 MHz.
Intensity Variation	< 1 dB
Diffraction Efficiency	>75 %, midband
Light Polarization	Linear, perpendicular to acoustic propagation
Acoustic Aperture Size	2 X 10 mm
Process Time	1.25 $\mu$ s with 7.2 mm beam size in acoustic direction
Resolution (T.BW product)	60 spots
$\Delta$ Deflection Angle	3 mrad
Deflection Angle	7.7 mrad @ 125 MHz
RF Power Level	4 Watts
Impedance	50 Ohms
VSWR	<1.5:1 across bandwidth
Package:	53B1289
Recommended Driver:	
	Analog System Voltage Controlled Oscillator: 64090-150-7ASVCO
	Analog Module Voltage Controlled Oscillator: 64090-150-7AMVCO

### SECTION IV OUTLINE DRAWING

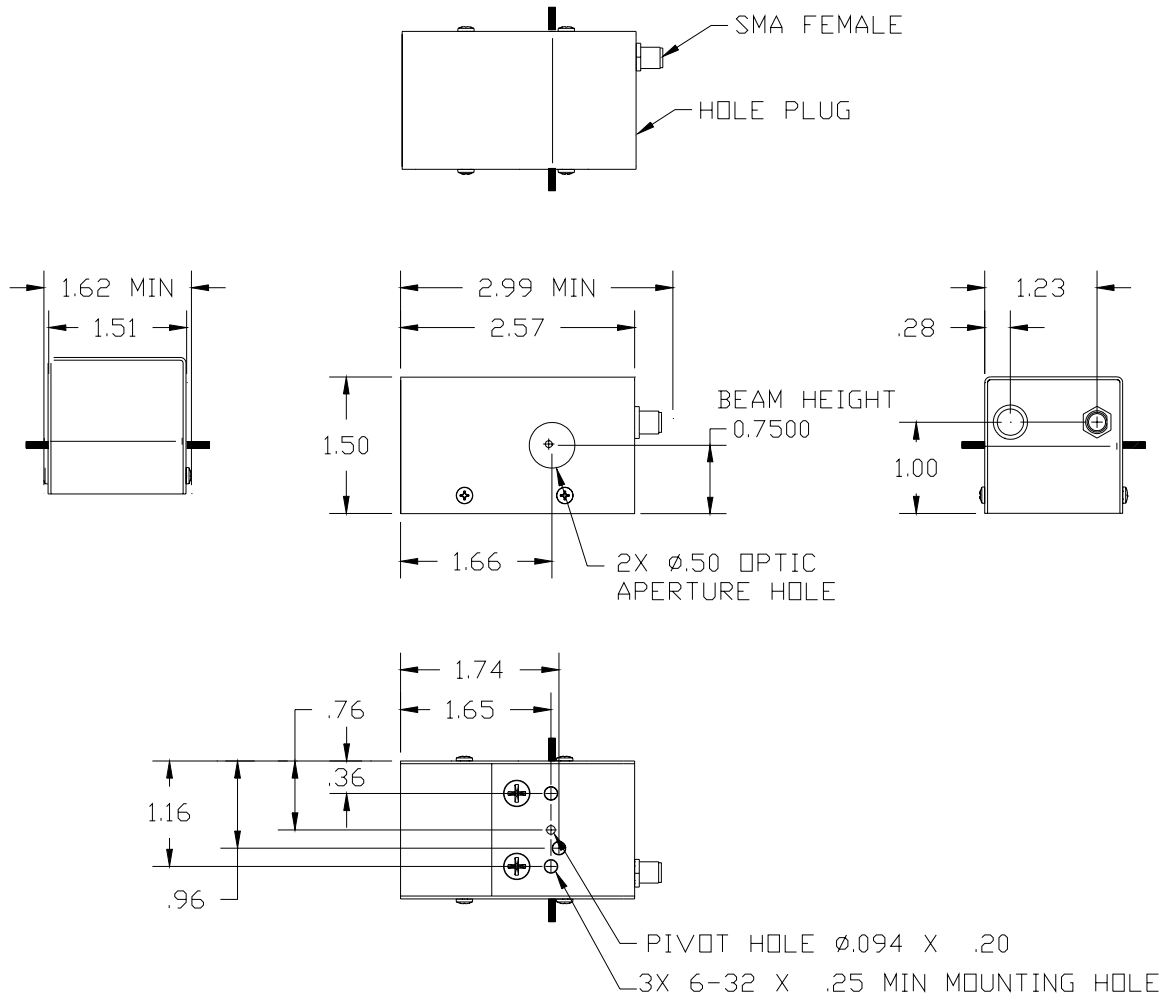

53B1289

Dimensions are in inches

Dimensions in [ ] are in mm.

Tolerances: Decimal: .xx = .01      .xxx = .005

Milimeter: .xx = .25mm      .xxx = .127mm

Angle: = ± 30'

## SECTION V CALCULATIONS

The maximum aperture of the device is 2 millimeters by 10 millimeters. The laser beam diameter should be the required size necessary to achieve the proper scan resolution. The RF bandwidth ( $\Delta f$ ) of the device is 50 MHz.

- The access time ( $\tau$ ) can be determined from the following:

$\tau$  = Beam diameter in mm in the acoustic direction divided by 5.750 mm / microsecond

$$\frac{7.2}{5.75} = 1.25 \mu\text{s}$$

- The number of resolvable spots (TBW) for Acousto-Optic Beam Deflector is the product of  $\Delta f$  and  $\Delta T$   
Where: the RF bandwidth ( $\Delta f$ ) of the device is 50 MHz.

$$\text{TBW} = \Delta f \Delta T = f \text{ and } \tau = 50 \text{ MHz} \times 1.25 \mu\text{s} = 62$$

62 resolvable spots

- The actual number of resolvable spots (N) are dependent on the uniformity of the illumination of the aperture (truncation of the laser beam) and scan chirp time.

$$N = \left(1 - \frac{\Delta T}{T + \Delta T}\right) \left(\frac{\Delta T \Delta f}{a}\right)$$

Where: T = Chirp time

$\Delta T$  = process time

a = A parameter for uniformity of illumination.

Where: a = 1 for uniform illumination.

a = 1.34 for gaussian illumination clipped at the  $\frac{1}{e^2}$  intensity points.

- The RF chirp applied to the AOBD causes a lensing effect as well as a deflection of the laser beam. The focal length ( $FL_a$ ) of the acoustic cylinder lens, lensing effect is:

$$FL_a = V_a^2 / \left(\frac{d f a}{d t} \cdot \lambda\right)$$

Where:  $\frac{d f a}{d t}$  is the slope of the frequency change vs time.

- The angle between the diffracted and the zero order beam, the deflection angle,  $\varnothing_d$ , is defined by:

$$\varnothing_d = 2\theta_{\text{Bragg}} = \frac{\lambda f}{V} = \frac{f 10^6 \times \lambda}{5.75 \text{ m/sec}}$$

f = RF frequency in MHz

$\lambda$  = optical wavelength

$\theta$  = Bragg angle

The frequencies for this device are from 100 to 150 MHz with 125 MHz as center frequency.

Example1:

$$\frac{125 \times 0.355}{5.75} = 7.7 \text{ mrad}$$

Example2:

$$\frac{150 \times 0.355}{5.75} = 9.26 \text{ mrad}$$

Example3:

$$\frac{100 \times 0.355}{5.75} = 6.2 \text{ mrad}$$

## SECTION VI.

### OPERATING PROCEDURE

Connect to the AOBD, a RF source that will provide nominally 4 Watt of CW RF power between the frequencies between 100 and 150 MHz.

Project a collimated light beam, with linear, perpendicular polarization with respect to acoustic propagation into the aperture of the AOBD. The light beam should fully fill the aperture in order achieve the full output resolution. Rotate the AOBD Bragg angle so that the diffracted beam is normal to the input window of the SiO<sub>2</sub> crystal. Apply the RF power at 125 MHz to the AOBD. Adjust the Bragg angle and view the output light at a distance of about 1 meter from the output side of the AOBD, as an array of spots will result when approaching the Bragg angle. Use a fluorescence card or a UV viewing scope to see the beam.

When this array of spots becomes evident, maximize the intensity of the diffracted (+) first order beam (away from the SMA connector), by varying Bragg angle, the vertical and horizontal position of the AOBD. Refer to figure 1. The vertical positioning of the deflector is important to ensure that the light beam is centered in the acoustic column. In most AOBD's you may also see some diffracted light in the negative first and negative second orders, however the intensity of these orders are generally very low when the AOBD is set at the Bragg angle.

Next, check the diffraction efficiency at 100 MHz and 150 MHz RF drive frequencies or sweep the RF over this 50 MHz band. Slightly adjust the three adjustments to obtain best flatness diffracted light intensity across the band of 100 to 150 MHz.

Next, the RF power should be adjusted to achieve the maximum required diffraction efficiency. However, in no case should the RF power exceed (10) watts, NEOS will not warranty any failure resulting from the application of too much RF power.

This device has been produced and tested to meet or exceed the specifications.

Figure 1  
AOBD Bragg Angle Adjustment

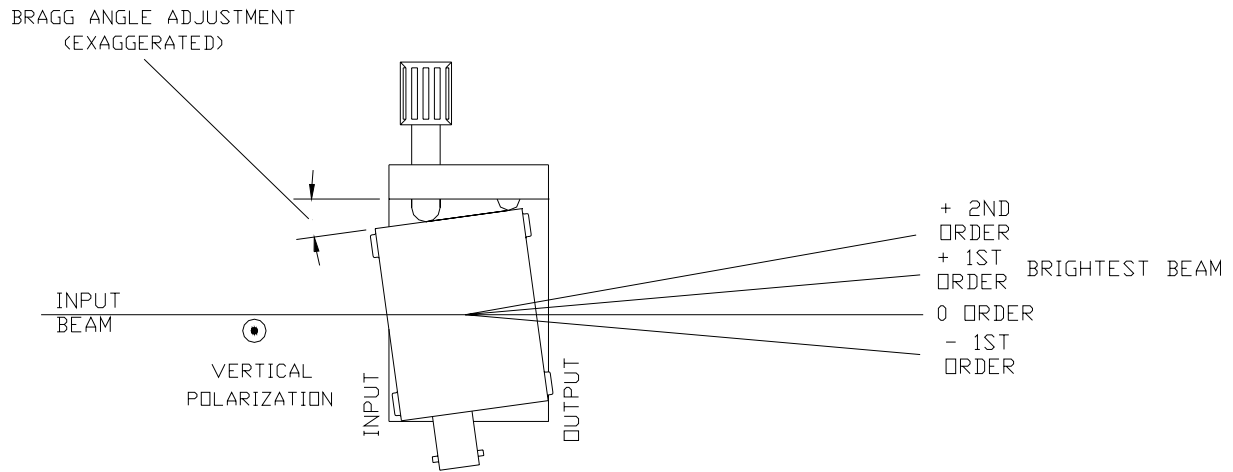

## SECTION VII. CLEANING PROCEDURE

Periodic cleaning of the AOBD's optical windows is a normal part of maintaining an optical system. When the AOBDs are installed in an optical system, make sure that there is access to allow cleaning or removal for cleaning of the AOBDs and it's mount from the system. When removed from the system, follow the alignment procedure in this manual to reinstall, realign and, adjust the AOBDs. Make sure that the AOBDs are reinstalled in the correct position as the devices are unidirectional.

To clean the AOBD device, remove the screws that hold the cover to the device. Caution must be used when placing a screw driver near the window opening in the cover, as it is best to protect the opening with tape or cover the opening with your finger (without touching the crystal) to protect it. NEOS will not warrant any damage or scratches caused by inserting the screwdriver into the window opening.

- Remove the protective cover.
- Blow off any visible dust with canned air. Do not use an air gun unless it is filtered and water and oil free!
- Fold (4 times) a new lens tissue into a triangle to make a cleaning tool.
- Dip the tip of the lens tissue into fresh acetone or spray fresh acetone from a squeeze bottle onto it. Then shake excess fluid out of the lens tissue. Do not handle the wet area of the tissue, as your finger oil will be absorbed and contaminate the optical surface of the crystal.
- Wipe (only once) across the crystal window in an even motion, starting near the transducer and drawing the tissue across the optical surface toward the other end. Do not damage the bond wires! Do not reuse the tissue as the mounting silver epoxy may be spread onto the window of the crystal.
- Repeat with a new tissue each time and for each surface that needs cleaning.
- Replace the AOBD cover and screws.
- Realign the AOBDs in your system and adjust the Bragg angle for maximum diffraction efficiency.

### Notes:

- The lens tissue must be lint free and the best grade available.
- Only use each tissue once, for only one surface. Do not reuse the tissue, as it will redistribute the removed dust or mounting silver epoxy.
- The acetone must be electronic grade. The acetone must be fresh from a new bottle, as the acetone will absorb water from the air and cause streaks. Discard any acetone, which has been exposed to the air for more than 4 hours. If the bottle is half- empty, do not use.