



NEOS TECHNOLOGIES

A Gooch & Housego Company

OPERATING MANUAL
ANALOG DRIVER SYSTEM
MODEL NUMBER:

11440-0.8AS

DOCUMENT NUMBER: 51A17680A

Document approved for release: W Seale Date: 11/11/05

US OFFICE: NEOS Technologies, Inc. ♦ 4005 Opportunity Drive ♦ Melbourne, FL 32934 ♦ USA
Tel: (321) 242-7818 ♦ Fax: (321) 242-1019 ♦ Email: neos@neostech.com

UK OFFICE: Gooch & Housego ♦ The Old Magistrates Court ♦ Ilminster, Somerset TA19 0AB ♦ UK
Tel: +44 1460 52271 ♦ Fax: +44 1460 54972 ♦ Email: sales@goochandhousego.com

TABLE OF CONTENTS

Section	Description	Page
I.	INSPECTION PROCEDURE	3
II.	DESCRIPTION	4
III.	SPECIFICATIONS	5
IV.	OUTLINE DRAWING	6
V.	CONTROLS AND CONNECTIONS	7
VI.	OPERATING PROCEDURES	8

SECTION I INSPECTION PROCEDURE

Examine the shipping carton for damage. If the shipping carton or packing material is damaged it should be kept for the carrier's inspection. Check the contents of the shipment for completeness, mechanical damage, and then test the equipment electronically. Operating procedures are contained in Section VI. Notify the carrier and NEOS Technologies. If the contents are incomplete, or the equipment does not pass the electrical testing please notify NEOS Technologies.

If there is any problem with the use of this equipment, or if the equipment fails to function as expected contact NEOS Technologies, do not try to trouble shoot or repair this equipment. Consult with a NEOS service engineer. If the equipment needs repair or replacement, contact NEOS Technologies, Inc for a Return Authorization Number.

SECTION II. DESCRIPTION

The model 11440-0.8AS is a RF frequency generator designed to supply a signal of 440 MHz at to, 800mW output typically, and is used to drive the NEOS Technologies 17440 acousto optic modulators.

The output signal can be modulated by a 0 to 1 Volt analog external signal applied to the Analog Modulation input when the switch on the front panel is in the normal position.

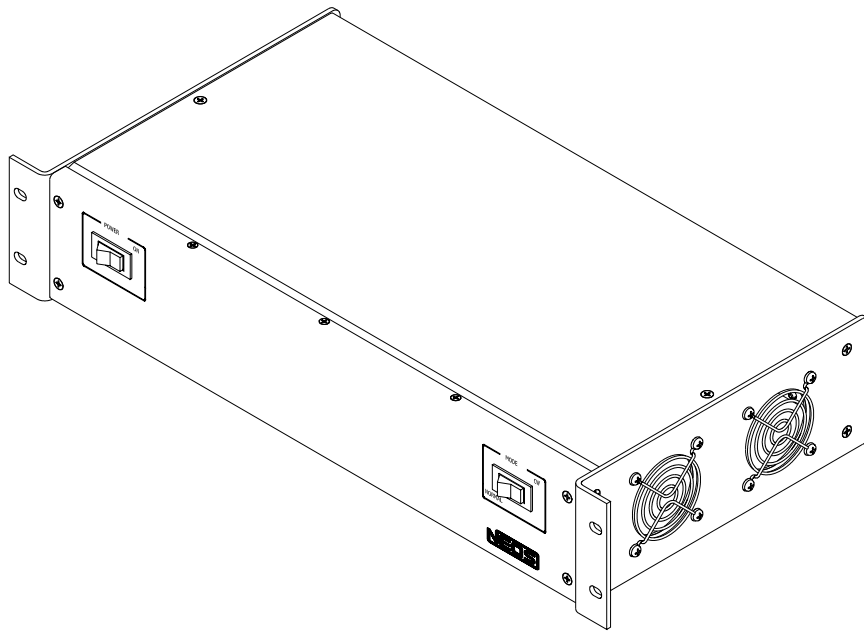

11440-0.8AS

53D1702

ANALOG DRIVER SYSTEM

SECTION II SPECIFICATIONS

11440-0.8AS

PARAMETER:	SPECIFICATION:
OUTPUT FREQUENCY:	440 MHz \pm 0.01% Quarts stabilized.
SPURIOUS LEVELS:	-50dBc Maximum
HARMONIC DISTORTION:	-15 dBc Maximum
ANALOG MODULATION INPUT:	0 TO \pm 1Volt Analog \pm 1 Volt = Full RF Power 0 Volt = Minimum RF Power
EXTINCTION RATIO:	35 dB Minimum
RF RISE :	4 ns Maximum $P_{RF} = 10$ TO 90 %
FALL TIME	4 ns Maximum $P_{RF} = 90$ TO 10 %
RF OUTPUT POWER:	800 mW Typical .3 to .8 Watts adjustable, Typical Factory adjusted to match the AO device for best performance.
SUPPLY VOLTAGE:	100 to 240 Volts AC
SUPPLY CURRENT:	1.5 Amp Maximum
<u>MAXIMUM RATINGS:</u>	
SUPPLY VOLTAGE:	264 Volts
POWER OUTPUT:	No DC Feedback Allowed.
AMBIENT TEMPERATURE:	+45 °C
<u>CONNECTORS AND MECHANICAL:</u>	
RF OUTPUT CONNECTOR:	BNC Female
MODULATION INPUT CONNECTOR:	BNC Female
POWER INPUT CONNECTOR:	3 PIN IEC Panel Mount, EMI filtered
<u>RELATED DOCUMENTS:</u>	
OUTLINE DRAWING:	53D1702
ACCEPTANCE TEST REPORT FORM:	52A17682

**SECTION V
CONTROLS AND CONNECTIONS**

FRONT

53D1702

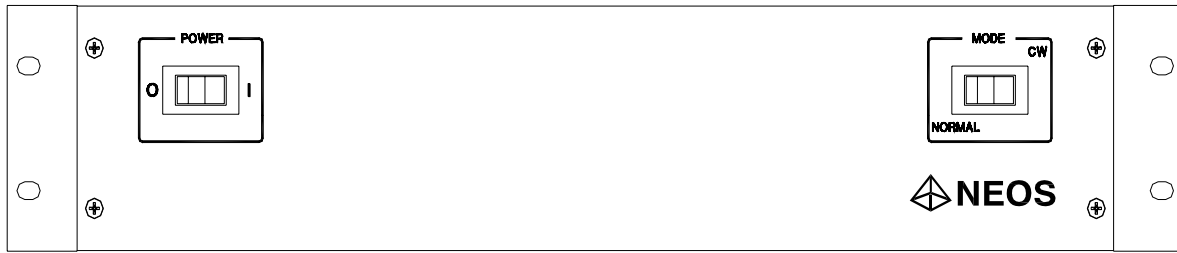

A. Power Switch

Turns on primary power.

B. Mode Switch

1. In the "CW" position the RF is always full ON.
2. In the "NORMAL" position the RF output will follow the modulation signal applied.

REAR

53D1702

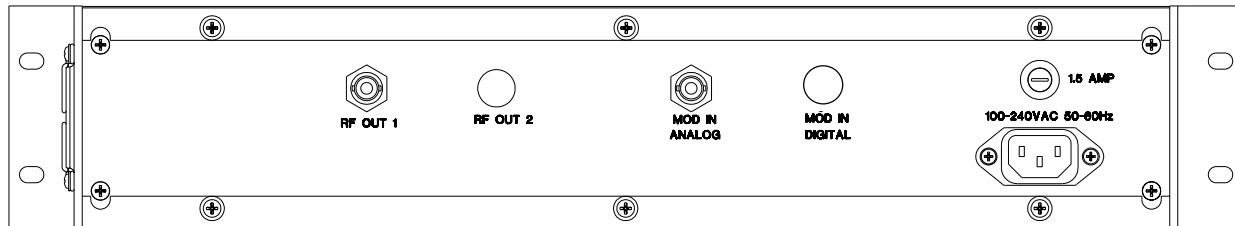

A. RF Out

System Output - The frequency is 440 MHz at 800 mW typical. It must be terminated with a 50 Ohm load capable of dissipating 1 watt or an acousto optic modulator device.

B. Modulation Input

The modulation input accepts analog 0 to +1 Volt signal into 50 Ohm. 1 Volt is full ON and a "0" is OFF. All above signals are referenced to the shield of the BNC connector.

C. Level Adjust (inside the internal module)

The level adjust is a factory adjustment and is in the module internal to the system.

SECTION VI. OPERATING PROCEDURES

TESTING PROCEDURE:

With the power off, attach a 50 Ohm load capable of dissipating 1 Watt to the "RF Output" of the unit.

Turn the power switch on.

With the front panel "MODE" switch in the "CW" position:

Measure the frequency and output power of the driver. (Note: power is factory pre-set to match the NEOS AO device for optimum performance and is listed on the AO device Acceptance Test Results form. Other parameters are listed on the Acceptance Test Results form included with this driver.

Adjust, if necessary, the output power to the power level necessary for the AO device to be driven. The adjustment is internal to the module inside the system box.

Warning: The RF power should never exceed that specified for the AO device driven. See the AO device manual for power limitations and other warnings. If damage results due to overpowering the AOM, the warranty will be void.

Apply an external 0 to +1 Volt analog modulating signal to the Modulation Input.

With the front panel "MODE" switch in the "NORMAL" position:

Measure RF output for specifications for this driver as listed in the Acceptance Test Results form included with this driver.

The driver has been designed and has been tested to meet the specification. Notify NEOS Technologies, Inc if the driver does not pass the electrical testing.

OPERATION PROCEDURE:

To use the driver, with the power off, attach the NEOS 17440 acousto optic modulator device to the driver with a 50 Ohm cable.

Turn on the power switch.

With the front panel "MODE" switch in the "CW" position:

Follow the instructions in the device manual to align and adjust the optical modulator as required.

With the front panel "MODE" switch in the "NORMAL" position:

Apply an external 0 to +1 Volt analog signal to the Modulation Input as desired.