



NEOS TECHNOLOGIES

A Gooch & Housego Company

OPERATING MANUAL

AO MODULATOR

MODEL NUMBER:

35085-0.5

OR

35085-0.5-350

DOCUMENT NUMBER: 51A16073

Document approved for release: W Seale Date: 4/14/07

US OFFICE: NEOS Technologies, Inc. ♦ 4005 Opportunity Drive ♦ Melbourne, FL 32934 ♦ USA

Tel: (321) 242-7818 ♦ Fax: (321) 242-1019 ♦ Email: neos@neostech.com

UK OFFICE: Gooch & Housego ♦ The Old Magistrates Court ♦ Ilminster, Somerset TA19 0AB ♦ UK

Tel: +44 1460 52271 ♦ Fax: +44 1460 54972 ♦ Email: sales@goochandhousego.com

TABLE OF CONTENTS

SECTION	TITLE	PAGE
I	INSPECTION	3
II	DESCRIPTION	4
III	SPECIFICATIONS	5
IV	OUTLINE DRAWINGS	6
V.	CALCULATIONS	7
VI	OPERATING PROCEDURE	9
VII.	CLEANING PROCEDURE	10

SECTION I
INSPECTION PROCEDURE

Examine the shipping carton for damage. If the shipping carton or packing material is damaged it should be kept for the carrier's inspection. Notify the carrier and NEOS Technologies of any damage. Check the contents of the shipment for completeness, mechanical damage, and then test the equipment electronically. Operating procedures are contained in Section V. If the contents are incomplete, or the equipment does not pass the electrical testing please notify NEOS Technologies.

If there is any problem with the use of this equipment, or if the equipment fails to function as expected contact NEOS Technologies, do not try to trouble shoot or repair this equipment. Consult with a NEOS service engineer. If the equipment needs repair or replacement, contact NEOS Technologies, Inc for a Return Authorization Number.

SECTION II

DESCRIPTION

35085-0.5 or 35085-0.5-350

The modulator system is a fused silica optical cell with a Lithium Niobate transducer. The RF input should not exceed six (6) watts CW. The 35085-05 modulator system is optimized for the use from 400 nm to 540 nm wavelengths with a beam diameter of 0.5 millimeters or less. The 35085-05-350 modulator system is optimized for the use from 300 nm to 400 nm wavelengths with a beam diameter of 0.5 millimeters or less. Other wavelengths can be used, however, diffraction efficiency will degrade with longer wavelengths as a function of $1/\lambda^2$.

The modulator assembly should be mounted on a fixture to provide sufficient adjustment to peak the modulator efficiency. This AOM can be purchased with a Bragg angle mount, model 72005, that allows convenient adjustment of the Bragg angle. The modulator can be driven by any good driver with a nominal 50 ohms output. However, it is recommended that a NEOS driver be used to drive this modulator for the system to achieve optimum performance.

**SECTION III
SPECIFICATIONS**

<u>PARAMETER</u>	<u>SPECIFICATION</u>	
Interactive Material	Fused Silica	
Acoustic Mode	Longitudinal	
Operating Wavelength for model number:	(35085-0.5) 400 to 540 nm,	(35085-0.5-350) 300 to 400 nm
Window Configuration	AR Coated	
Static Transmission	>98 %	
Operating Frequency	85 MHz	
Diffraction Efficiency	>85 % With light polarized linear, perpendicular to acoustic propagation.	
Acoustic Aperture Size	0.5 mm	
Rise Time	110 ns / mm Beam Diameter	
Deflection Angle	6.9 mrad @ 488 nm, 5 mrad @ 350 nm	
RF Power Level	6 watts @ 488 nm, 3 watts @ 350 nm	
Impedance	50 ohms nominal	
VSWR	<1.2:1 @ 85 MHz	
Package:	53B1428	
Acceptance Test Procedure:	42A12035	
Acceptance Test Results form:	52A00936	
Recommended Driver:		
Analog Driver System: 31085-6AS	Digital Driver System: 31085-6DS	
Analog Driver Module: 31085-6AM	Digital Driver Module: 31085-6DM	

SECTION V
CALCULATIONS

- The equations to determine the AOM rise time "t_r" are as follows:

First determine the waist size by the equation, $d_0 = \frac{4f\lambda}{\pi d_1}$

Where: f = lens focal length in mm

λ = the optical wavelength in 10^{-6} m

d₁ = the input optical beam diameter in mm

d₀ = the waist diameter inside the modulator in 10^{-6} m

Knowing the waist size inside the modulator, then the modulator rise time can be calculated from the relationship:

$$t_r = \frac{1.3d_0}{2V}$$

Where: V = the acoustic velocity of the modulator material which is 5960 m/s

The focal length of the lens to produce the rise time is the F# of the lens times the input spot diameter:

$$F\# d_1 = f_{\text{lens}}$$

Note: The beam waist inside the modulator will affect diffraction efficiency of the modulator.

- The deflection angle " \varnothing_d " is defined as the acoustic drive frequency in megahertz times the wavelength, divided by the acoustic velocity of the material:

$$\varnothing_d = 2\theta_{\text{Bragg}} = \frac{f_a \lambda}{V} = \frac{85 \times 10^6 \lambda}{5960 \text{ m/sec}}$$

Where: θ_{Bragg} = Bragg angle of the modulator.

Figure 2

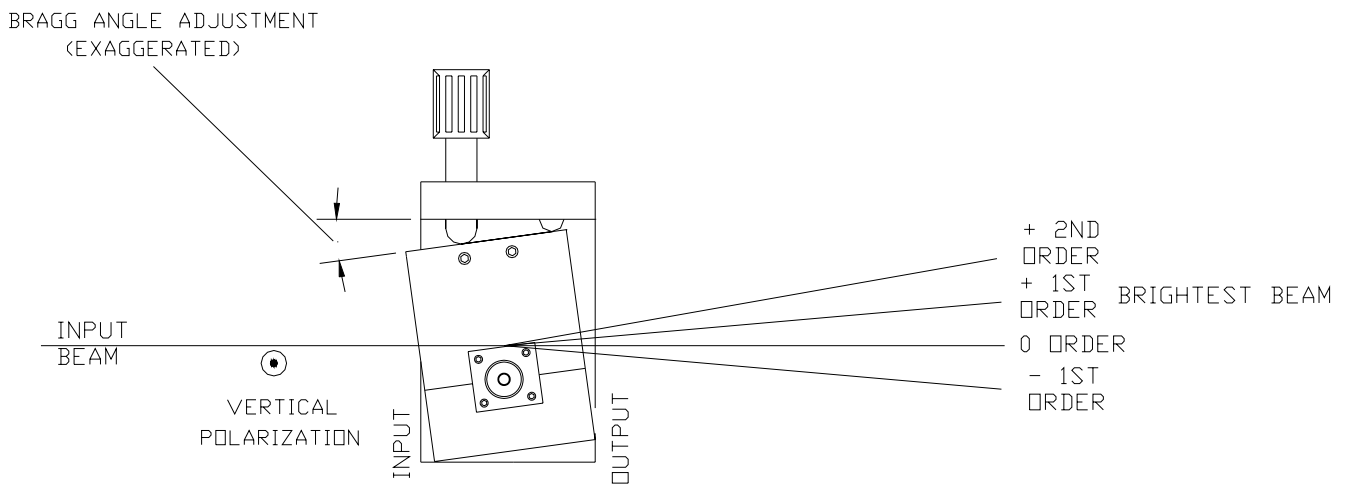

AOM BRAGG ADJ.

45A18402

SECTION V

OPERATING PROCEDURE

Mount the modulator in the optical path with the laser beam passing through the device window centered on the window vertically and close to the transducer. It does not matter which aperture the incident light enters the AOM. The modulator requires linear polarization, oriented perpendicular to the acoustic propagation axis. Random polarization may be used but will have reduced efficiency. The modulator mount assembly must have sufficient adjustments to peak the modulator efficiency (Bragg angle, horizontal, and vertical position). Lenses may be required to achieve the rise time desired. Be extremely careful not to focus the laser beam on the gold bond wires on the acoustic transducer, which may vaporize the bond wires. NEOS will not warranty any such damage.

Using a 50 Ohm coaxial cable, connect the "RF out" of the driver to the modulator. Turn on the RF power. If using the NEOS driver system, be sure the mode switch is in the CW position. Make sure that the RF power does not exceed 6 Watts. NEOS will not warranty any failure resulting from the application of too much RF power.

With the laser beam centered approximately on the optical crystal, and close to the transducer, adjust the Bragg angle. At a distance of about one meter from the output side the AOM, an array of light spots will result when approaching the Bragg angle. When this array becomes evident, maximize the intensity of the diffracted first order beam, by varying the vertical and horizontal position and by rotating the modulator, to allow the diffracted first order beam away from the transducer to be the most intense. See figure 2.

A lens is needed to archive a faster rise time. Install the input lens, one "f" away, and adjust the height of the modulator to achieve diffraction again. Make changes in the Bragg adjustment screw to obtain optimum efficiency. Adjust, if necessary, the RF driver for power level to obtain maximum diffraction efficiency. If the driver and modulator are purchased together, the driver will be adjusted for optimum performance before shipment. Install the output lens, one "f" away, to collimate the output beam. The modulator has been designed and verified to satisfy the specifications.

To operate the modulator, use the first order diffracted beam with the driver mode switch set to normal. See the driver manual for signals required for modulation.

SECTION VIII.

OPTICAL CLEANING

Periodic cleaning of the AO device is a normal part of maintaining an optical system. When the device is installed in an optical system, make sure that there is access to allow removal of the protective cover and room to clean the device. If removal from the system is necessary, then follow the alignment procedure in this manual to reinstall, realign and, adjust the AO device.

To clean the AO device, remove the screws that hold the sides to the mount. Caution must be used when placing a Allan driver near the window opening in the cover, as it is best to protect the opening with tape or cover the opening with your finger (without touching the crystal) to protect it. NEOS will not warrant any damage or scratches caused by inserting the screwdriver into the window opening.

- Blow off any visible dust with canned air. Do not use an air gun unless it is filtered and water and oil free!
- Fold (4 times) a new lens tissue into a triangle to make a cleaning tool.
- Dip the tip of the lens tissue into fresh acetone or spray fresh acetone from a squeeze bottle onto it. Then shake excess fluid out of the lens tissue. Do not handle the wet area of the tissue, as your finger oil will be absorbed and contaminate the optical surface of the crystal.
- Wipe (only once) across the crystal in an even motion, starting near the transducer and drawing the tissue across the optical surface toward the other end. Do not damage the bond wires! Do not reuse the tissue as the mounting silver epoxy may be spread onto the window of the crystal.
- Repeat with a new tissue each time and for each surface that needs cleaning.
- Replace the protective sides and screws.
- Realign the device in your system and adjust the Bragg angle for maximum diffraction efficiency.

Notes:

- The lens tissue must be lint free and the best grade available.
- Only use each tissue once, for only one surface. Do not reuse the tissue, as it will redistribute the removed dust or mounting silver epoxy.
- The acetone must be electronic grade. The acetone must be fresh from a new bottle, as the acetone will absorb water from the air and cause streaks. Discard any acetone, which has been exposed to the air for more than 4 hours. If the bottle is half- empty, do not use.