



NEOS TECHNOLOGIES

A Gooch & Housego Company

OPERATING MANUAL

INTEGRATED 1 X 1 DUAL BAND SWITCH

MODEL NUMBER:

54035/34.12-1.55/1.59-.5DS-1CH

DOCUMENT NUMBER: 51A14253B

APPROVED: W. Seale DATE: 12/17/02

US OFFICE: NEOS Technologies, Inc. ♦ 4005 Opportunity Drive ♦ Melbourne, FL 32934 ♦ USA

Tel: (321) 242-7818 ♦ Fax: (321) 242-1019 ♦ Email: neos@neostech.com

UK OFFICE: Gooch & Housego ♦ The Old Magistrates Court ♦ Ilminster, Somerset TA19 0AB ♦ UK

Tel: +44 1460 52271 ♦ Fax: +44 1460 54972 ♦ Email: sales@goochandhousego.com

TABLE OF CONTENTS

SECTION	TITLE	PAGE
I.	INSPECTION PROCEDURE	3
II.	DESCRIPTION	4
III.	SPECIFICATIONS	5
IV.	OUTLINE DRAWING	6
V.	CONNECTIONS AND CONTROLS	7
VI.	OPERATING PROCEDURE	8
VII.	BLOCK DIAGRAM	9

SECTION I INSPECTION PROCEDURE

Examine the shipping carton for damage. If the shipping carton or packing material is damaged it should be kept for the carrier's inspection. Check the contents of the shipment for completeness, mechanical damage, and then test the equipment electronically. Operating procedures are contained in Section VI. Notify the carrier and NEOS Technologies. If the contents are incomplete, or the equipment does not pass the electrical testing please notify NEOS Technologies.

If there is any problem with the use of this equipment, or if the equipment fails to function as expected contact NEOS Technologies, do not try to trouble shoot or repair this equipment. Consult with a NEOS service engineer. If the equipment needs repair or replacement, contact NEOS Technologies, Inc for a Return Authorization Number.

SECTION II

INTEGRATED 1 X 1 DUAL BAND SWITCH

54035/34.12-1.55/1.59-.5DS-1CH

The INTEGRATED 1 X 1 DUAL BAND SWITCH consists of an acousto-optic modulator (AOM) assembly with a highly efficient acousto-optic modulator that is fiber coupled out with single mode fibers, a selectable dual frequency RF driver, and a universal power supply to supply the needed power.

The AOM is not direction sensitive, so either fiber can be used for input or output. The standard configuration couples the diffracted plus first order out of the AOM. The standard fiber connector used is the FC/PC with 9/125 single mode fiber. The AOM is designed for operation at C Band 1520 to 1570nm and L Band 1570 to 1620nm. Its operation is independent of optical polarization. The C Band output will have the light frequency shifted up by 35MHz from the light frequency applied at the input. The L Band will have the light frequency shifted up by 34.12MHz from the light frequency applied at the input. The low loss path will be when the RF driver is turned on.

The NEOS dual frequency RF driver is designed to provide the needed 35MHz and the 34.12 MHz RF power for the AOM. The RF power is set to 0.5 watts. The front panel has a "MODE" switch, which allows the system to be turned on "CW" producing a low loss optical path through the system without external input. With the front panel "MODE" switch in the "NORMAL" position the driver can be modulated with a digital TTL signal and an analog 0 to 5 volt signal. The digital is internally pulled "high" which causes the driver to apply RF power to the AOM and produces a low loss path through the fiber. It requires a TTL "low" to turn it off. The RF power output to the AOM follows the analog modulation voltage input and can be used to attenuate the output optical signal. This analog signal is required for the optical signal to be output with the "MODE" switch in the "NORMAL" position. A 5 Volt signal is full on.

The operating band is shifted by applying a TTL "low" to the "Osc Select" input pin of the 9 Pin connector, shifting the frequency from C Band to L Band. A TTL "high" or no connection will shift the band to C Band. The Band can be selected with the "MODE" switch in either position. See Figure 2 for the input control signal pinout.

SECTION III
SPECIFICATIONS
54035/34.12-1.55/1.59-.5DS-1CH

<u>PARAMETER</u>	<u>SPECIFICATION</u>
Channels	1Channel
Interactive Material	AMTIR (GeSeAs)
Acoustic Mode	Longitudinal
Operating Wavelength	C Band: 1520nm to 1570nm L Band: 1570nm to 1620nm
Window Configuration	AR Coated
Operating Frequency	C Band: 35MHz L Band: 34.12MHz
CW Insertion Loss Excluding Connectors	2.4dB Maximum @ 1550nm 2.4dB Maximum @ 1590nm
Insertion Loss Variation Over Each Band Operating Wavelength	±0.125dB
Insertion Loss Variation Between CW to Modulated	±0.125dB
Back Reflection	-50dB
CW Extinction Ratio	55dB
Modulation Extinction Ratio (Modulation Frequency 125KHz)	40dB
Light Polarization	Random
Polarization Dependent Loss Over Operating Wavelength	0.15dB nominal 0.2dB Max.
Rise Time (10 to 90%)	100ns Maximum
Rise Time Symmetry	15%
Band Switching Time	150ns Maximum
Acoustic Optic Delay	1.35µs ± 0.2µs
Modulation Input	Analog 0-5Volts and Digital TTL
Band Control	Digital TTL
Power input	100 to 240 VAC, 50/60 Hz
Connector:	FC/PC
Fiber	Single Mode 9/125 Fiber
Package:	53D2246

**SECTION IV
PACKAGE OUTLINE DRAWING**

FIGURE 1

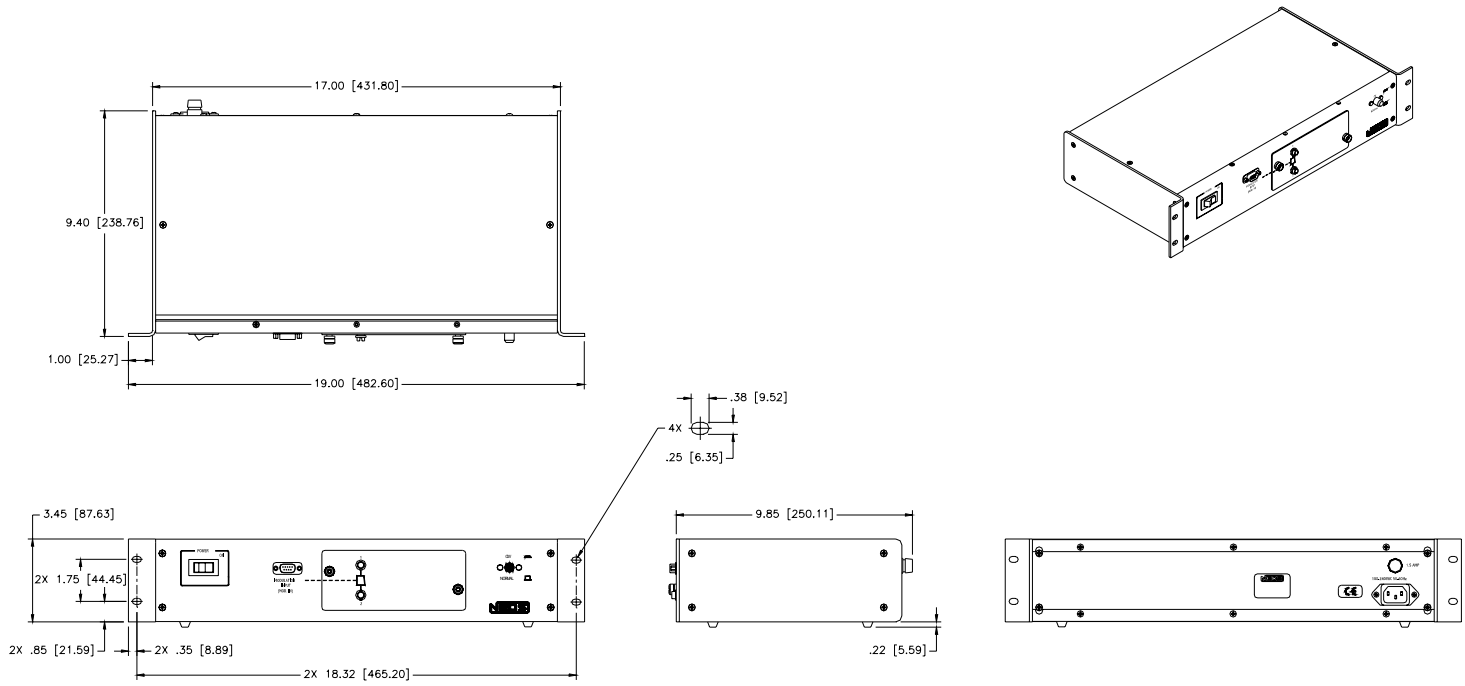

53D2246

54035/34.12-1.55/1.59-.5DS-1CH

Dimensions are in inches

Dimensions in [] are in mm.

SECTION V CONNECTION AND CONTROLS

Front Panel:

1. Power Switch: Applies the AC power and turns on the system.
2. 9 pin sub D Connector: Input for the control signals. See figure 2 for pinout.
3. (2) FC/PC Fiber Optical connectors: input and output with 9/125 fiber.
4. Mode Switch: "CW" or "NORMAL" mode.

"CW" produces a low loss path through the fiber and ignores the Digital and Analog external input signals.

"NORMAL" Requires an analog +5Volt or less (attenuating) signal and a Digital modulating signal to output an optical signal through the fiber.

Back Panel:

1. AC Power Connector: Accepts 100 to 240 Volts, 50 or 60Hz
2. Fuse Holder: Accepts a 1 Amp Fuse.

FIGURE 2

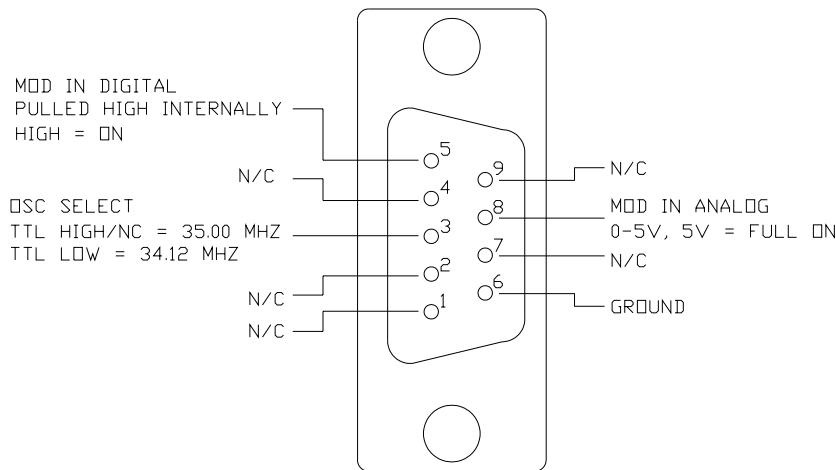

45A14243

9 Pin Sub D Input Control Signal Pinout Diagram

SECTION VI OPERATION PROCEDURES

1. Attach all needed signal lines to the 9 Pin Sub D Connector.
2. Attach the mating fiber connectors to the system. When attaching a mating fiber to the fibers on the system, be sure the connector end is clean. Cleaning the connector ends with a cotton swab soaked with acetone will ensure there will be a low loss, dirt free connection. The use of index matching fluid is recommended if minimal connection loss is needed.
3. Apply AC power to the system.
4. Turn on the power switch.

Testing System functions:

5. Set the "MODE" switch to "CW". The system should be now be set to the C Band and have a low loss path through the fiber.
6. Apply a TTL "low" to the "Osc. Select" pin 3 of the 9 Pin Control Connector. The system will now be set to the L Band and have a low loss path through the fiber.
7. Set the "MODE" switch to "NORMAL".
8. Apply both a 0 to 5Volt analog signal to pin 8 of the 9 Pin Control Connector to set the optical attenuation and apply a digital modulating TTL signal to pin 5 of the 9 Pin Control Connector to control the pass through or shutoff of the optical signal. Test the various specifications as listed on the Acceptance Test Report included with this manual. The system is designed to meet or exceed the specification.

Operation:

With the "MODE" switch in "NORMAL" position.

9. Apply a TTL control signal to the "Osc. Select" to select which optical Band is passed through the fiber.
10. Apply both a 0 to 5Volt analog signal to pin 8 of the 9 Pin Control Connector to set the optical attenuation and apply a digital modulating TTL signal to pin 5 of the 9 Pin Control Connector to control the pass through or shutoff of the optical signal as desired. The system is now operating.

SECTION VII BLOCK DIAGRAM

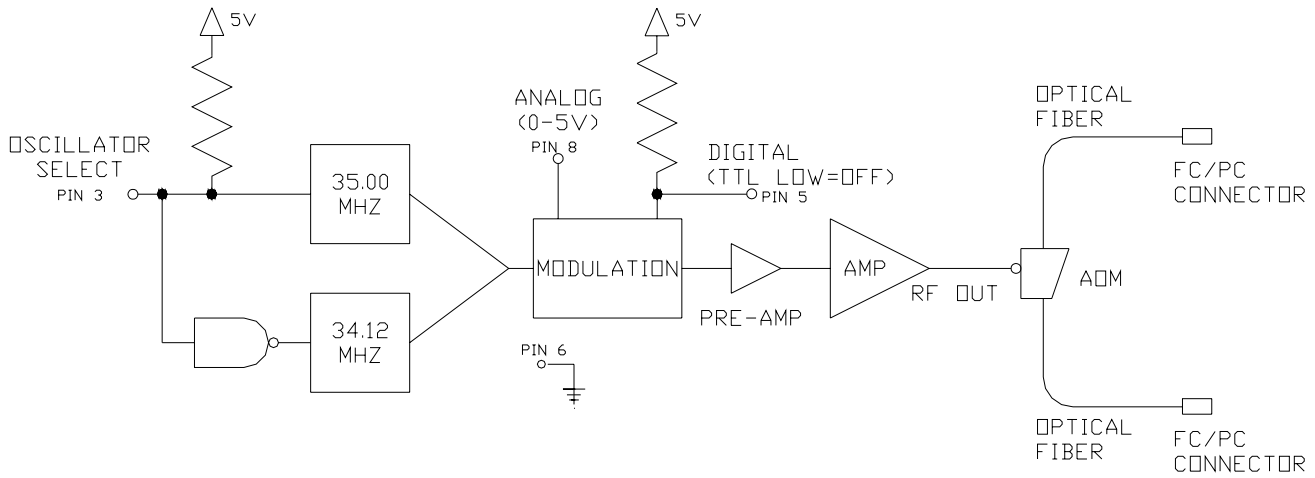

21A14247