



**NEOS TECHNOLOGIES**

A Gooch & Housego Company

OPERATING MANUAL

**100 MHz CENTER FREQUENCY OFF AXIS  
ACOUSTO-OPTIC BEAM DEFLECTOR  
MODEL NUMBER:**

**45100-5-6.5DEG-.51**

**DOCUMENT NUMBER: 51A12229A**

Document approved for release: W Seale      Date: 8/18/06

US OFFICE: NEOS Technologies, Inc. ♦ 4005 Opportunity Drive ♦ Melbourne, FL 32934 ♦ USA  
Tel: (321) 242-7818 ♦ Fax: (321) 242-1019 ♦ Email: [neos@neostech.com](mailto:neos@neostech.com)

UK OFFICE: Gooch & Housego ♦ The Old Magistrates Court ♦ Ilminster, Somerset TA19 0AB ♦ UK  
Tel: +44 1460 52271 ♦ Fax: +44 1460 54972 ♦ Email: [sales@goochandhousego.com](mailto:sales@goochandhousego.com)

**TABLE OF CONTENTS**

<u>SECTION</u>	<u>DESCRIPTION</u>	<u>PAGE</u>
I.	INSPECTION PROCEDURE	3
II.	DESCRIPTION	4
III.	SPECIFICATIONS	5
IV.	OUTLINE DRAWING	6
V.	CALCULATIONS	7
VI.	OPERATING PROCEDURE	8
VII.	CLEANING PROCEDURE	10

## **SECTION I**

### **INSPECTION PROCEDURE**

Examine the shipping carton for damage. If the shipping carton or packing material is damaged it should be kept for the carrier's inspection. Notify the carrier and NEOS Technologies. Check the contents of the shipment for completeness, mechanical damage, and then test the equipment electronically. Operating procedures are contained in Section VI. If the contents are incomplete, or the equipment does not pass the electrical testing please notify NEOS Technologies.

If there is any problem with the use of this equipment, or if the equipment fails to function as expected contact NEOS Technologies, do not try to trouble shoot or repair this equipment. Consult with a NEOS service engineer. If the equipment needs repair or replacement, contact NEOS Technologies, Inc for a Return Authorization Number.

## SECTION II DESCRIPTION

The off axis 45100-5-6.5DEG-.51 acousto-optic beam deflector (AOBD) is fabricated from  $\text{TeO}_2$  crystals with  $\text{LiNbO}_3$  slow shear wave transducers. The off axis deflector differs from the normal on axis deflector in that the acoustic beam is launched into the  $\text{TeO}_2$  6.5 degrees off of the 110 propagating axis. This design eliminates a mid-band degeneracy that results in a loss of diffraction efficiency over a narrow frequency range in the operating band of 75 MHz and 125 MHz.

. The AOBD can be driven by any good driver with a 50 ohm nominal output; however, it is recommended that a NEOS Technologies driver be used to drive this deflector to achieve optimum performance. The RF input power should not exceed 2.5 watts CW as NEOS Technologies will not warranty damage from RF power applied exceeding 2.5 watts

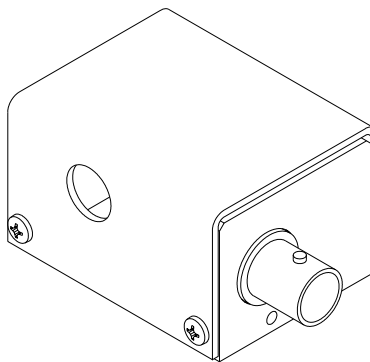

**45100-5-6.5DEG-.51**

53B2024

**SECTION III****DEVICE SPECIFICATIONS****45100-5-6.5DEG-.51**

<u>PARAMETER</u>	<u>SPECIFICATION</u>
Interactive Material	TeO <sub>2</sub>
Acoustic Mode	Shear Wave
Operating Wavelength	440 to 530nm
Window Configuration	AR Coated
Static Transmission	>95 %
Operating Frequency	75 to 125 MHz.
Intensity Variation	2dB
Diffraction Efficiency	>70% Midband
Light Polarization	Linear, parallel to acoustic propagation
Acoustic Aperture Size	5 mm
Process Time	7.5 $\mu$ s
Resolution (T.BW product)	375 spots with no less than 60 $\mu$ s scan time and full illumination of the aperture
$\Delta$ Deflection Angle	39 mrad @ 514 nm
Deflection Angle	78 mrad @ 100 MHz, 514 nm
RF Power Level	2 watt maximum
Impedance	50 ohms
VSWR	<2:1 across band
Package:	53B2024
Acceptance Test Procedure:	42A12652
Acceptance Test Results form:	52A11841

**Recommended Drivers:**

Analog System Digital Frequency Synthesizer: 64010-200-2ADSDFS-A

Analog Module Digital Frequency Synthesizer: 64010-200-2ADMDFS-A

Analog System Voltage Controlled Oscillator: 21075-125-2ASVCO

Analog Module Voltage Controlled Oscillator: 21075-125-2AMVCO

### SECTION IV OUTLINE DRAWING

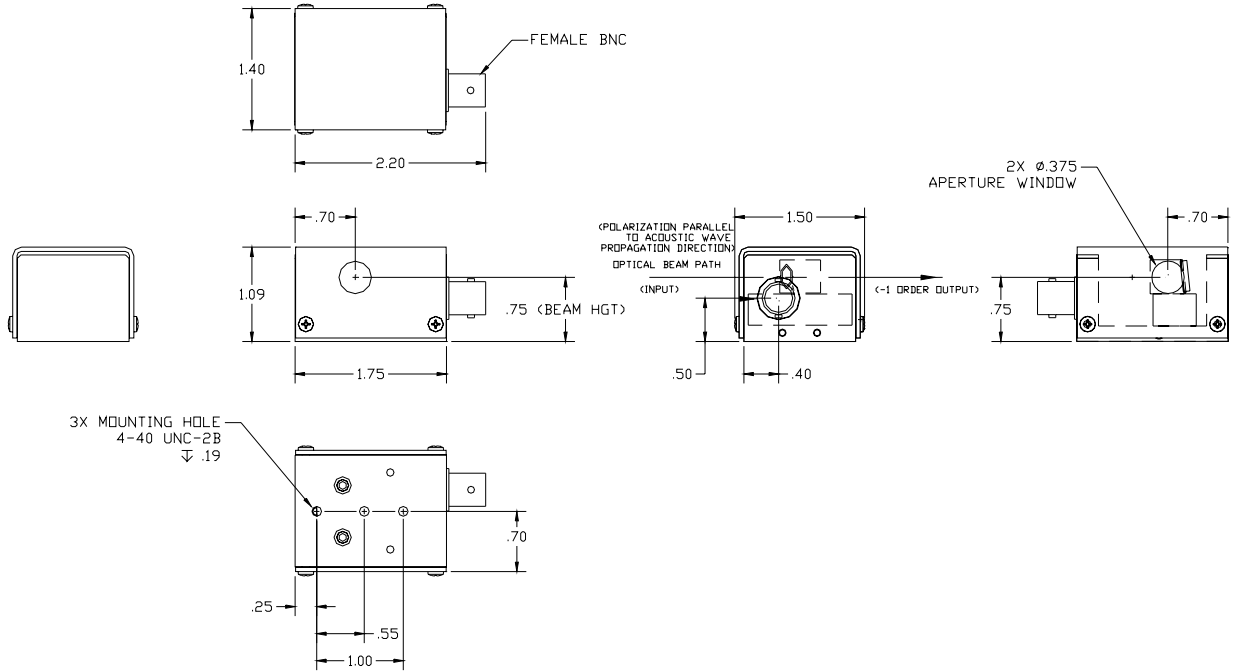

53B2024

Dimensions are in inches

Tolerances: Decimal: .xx = .01 .xxx = .005

Dimensions in [ ] are in mm.

Milimeter: .xx = .25mm .xxx = .127mm

Angle: =  $\pm 30'$

## SECTION V

### CALCULATIONS

The maximum aperture of each device is 5 millimeters by 5 millimeters. The input laser beam diameter should fully illuminate the aperture in order to achieve the proper number of resolvable spots. The access time ( $\Delta T$ ) can be determined from the following:

- The process time ( $\Delta T$ ) is equal to the Beam diameter ( $d_0$ ) in the acoustic direction divide by the Velocity of sound ( $V$ ) in the material.

$$\text{Where: } d_0 = 5 \text{ mm} \quad V = 0.66 \text{ mm}/\mu\text{s}$$

$$\Delta T = \frac{d_0}{V} = \frac{5}{0.66} = 7.5 \mu\text{s}$$

- The number of resolvable spots (TBW) for Acousto-Optic Beam Deflector is the product of  $\Delta f$  and  $\Delta T$   
Where: the RF bandwidth ( $\Delta f$ ) of the device is 50 MHz.

$$\text{TBW} = \Delta f \Delta T = 50 \text{ MHz} \times 7.5 \mu\text{s} = 375$$

375 resolvable spots with uniform illumination of the aperture and no less than 60  $\mu\text{s}$  chirp time to avoid lensing effects.

- The actual number of resolvable spots ( $N$ ) are dependent on the uniformity of the illumination of the aperture (truncation of the laser beam) and scan chirp time.

$$N = \left(1 - \frac{\Delta T}{T + \Delta T}\right) \left(\frac{\Delta T \Delta f}{a}\right)$$

Where:  $T$  = Chirp time

$\Delta T$  = process time

$a \equiv A$  parameter for uniformity of illumination.

Where:  $a = 1$  for uniform illumination.

$a = 1.34$  for gaussian illumination clipped at the  $\frac{1}{e^2}$  intensity points.

- The RF chirp applied to the AOBD causes a lensing effect as well as a deflection of the laser beam. The focal length ( $FL_a$ ) of the acoustic cylinder lens, lensing effect is:

$$FL_a = V_a^2 / \left(\frac{d f a}{d t} \cdot \lambda\right)$$

Where:  $\frac{d f a}{d t}$  is the slope of the frequency change vs time.

- The angle between the diffracted and the zero order beam, the deflection angle,  $\theta_d$ , is defined by:

$$\theta_d = 2\theta_{\text{Bragg}} = \frac{\lambda f}{V} = \frac{\lambda f}{0.66 \text{ mm}/\mu\text{sec}}$$

Where:  $f$  = RF frequency in MHz

$\lambda$  = optical wavelength

$\theta$  = Bragg angle of the Acousto-Optic Beam Deflector

The frequencies "f" are from 75 to 125 MHz with the center frequency = 100 MHz.

## SECTION VI.

### OPERATING PROCEDURE

Connect to the AOBD, a RF source that will provide nominally 2 Watt of CW RF power between the frequencies between 75 and 125 MHz with a 50 ohm cable.

Project a collimated light beam, linear polarized, parallel to acoustic propagation into the aperture of the AOBD on the input side (closest to the BNC connector ), as this device is unidirectional. The light beam should fully fill the aperture in order achieve the full output resolution. Rotate the AOBD Bragg angle so that the beam is normal to the input window of the TeO<sub>2</sub> crystal. Apply the RF power at 100 MHz to the AOBD. Adjust the Bragg angle as shown in figure 1 and view the output light at a distance of about 1 meter from the output side of the AOBD, as an array of spots will result when approaching the Bragg angle. Use a IR viewing card to see the output.

When this array of spots becomes evident, maximize the intensity of the diffracted (-) first order beam (toward the BNC connector), by varying Bragg angle, the vertical and horizontal position of the AOBD. Refer to figure 1. The vertical positioning of the deflector is important to ensure that the light beam is centered in the acoustic column. In most AOBD's you may also see some diffracted light in the positive first and negative second orders, however the intensity of these orders are generally very low when the AOBD is set at the Bragg angle.

Next, check the diffraction efficiency at 75 MHz and 125 MHz RF drive frequencies or sweep the RF over this 50 MHz band. Slightly adjust the three adjustments to obtain best flatness diffracted light intensity across the band of 75 to 125 MHz.

Next, the RF power should be adjusted to achieve the maximum required diffraction efficiency. However, in no case should the RF power exceed 2.5 watts, NEOS will not warranty any failure resulting from the application of too much RF power.

This device has been produced and tested to meet or exceed the specifications.

Note: The diffracted output beam will be rotated in polarized to be perpendicular to the acoustic propagation. This rotation in polarization is an advantage when using the device in the X-Y, 2D, AOBD configuration.

Figure 1  
AOBD Bragg Angle Adjustment

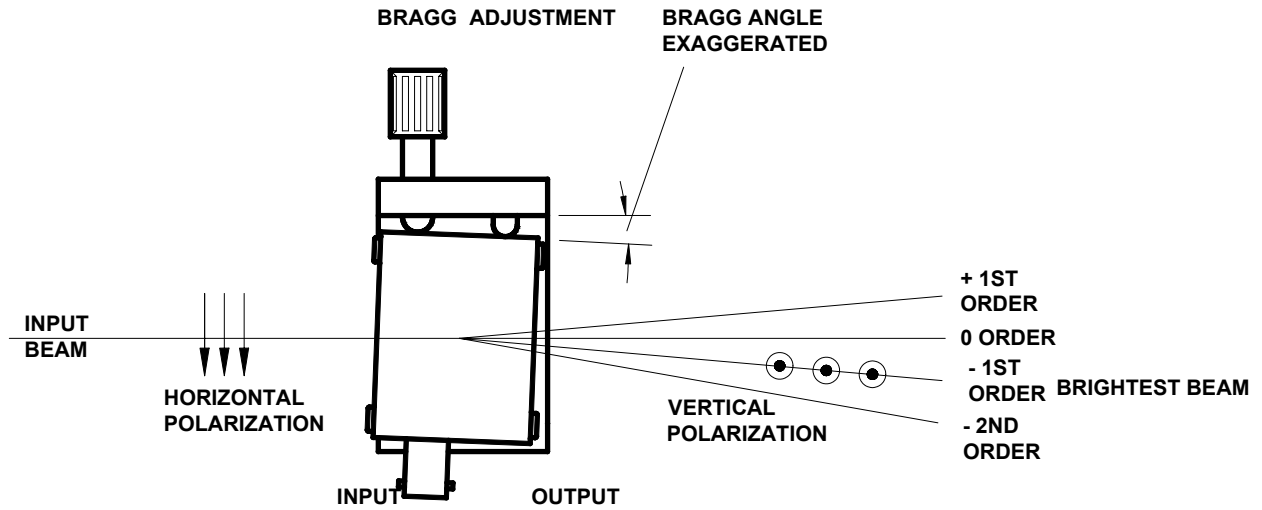

45A12233

Figure 2

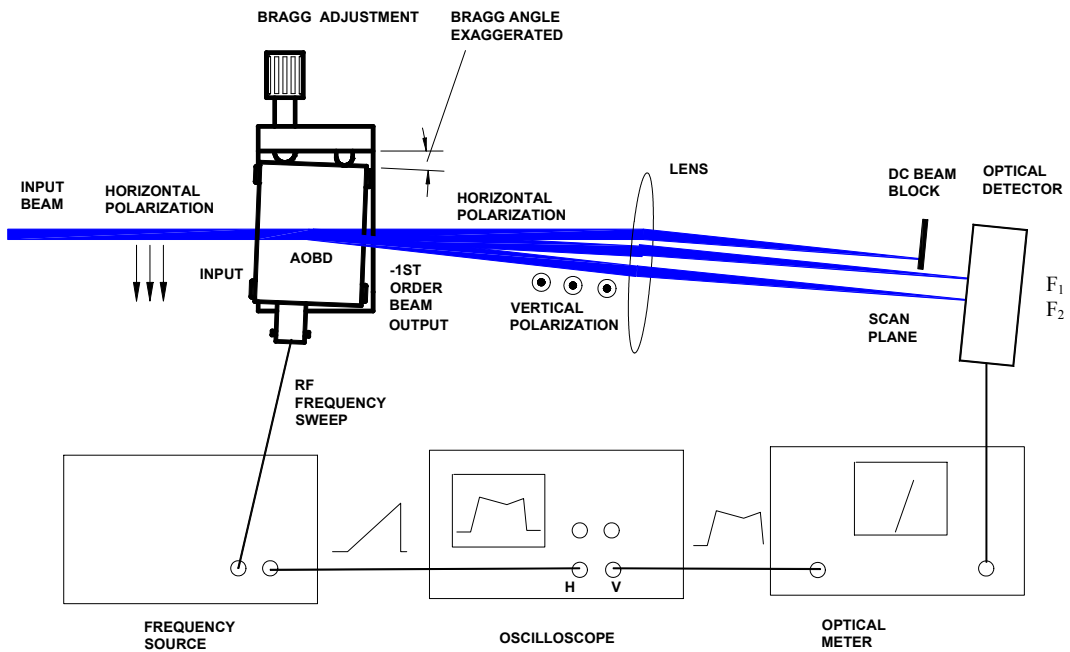

45A18969

## SECTION VII.

### CLEANING PROCEDURE

Periodic cleaning of the AOBD's optical windows is a normal part of maintaining an optical system. When the AOBDs are installed in an optical system, make sure that there is access to allow cleaning or removal for cleaning of the AOBDs and it's mount from the system. When removed from the system, follow the alignment procedure in this manual to reinstall, realign and, adjust the AOBDs. Make sure that the AOBDs are reinstalled in the correct position as the devices are unidirectional.

To clean the AOBD device, remove the screws that hold the cover to the device. Caution must be used when placing a screw driver near the window opening in the cover, as it is best to protect the opening with tape or cover the opening with your finger (without touching the crystal) to protect it. NEOS will not warrant any damage or scratches caused by inserting the screwdriver into the window opening.

- Remove the protective cover.
- Blow off any visible dust with canned air. Do not use an air gun unless it is filtered and water and oil free!
- Fold (4 times) a new lens tissue into a triangle to make a cleaning tool.
- Dip the tip of the lens tissue into fresh acetone or spray fresh acetone from a squeeze bottle onto it. Then shake excess fluid out of the lens tissue. Do not handle the wet area of the tissue, as your finger oil will be absorbed and contaminate the optical surface of the crystal.
- Wipe (only once) across the crystal window in an even motion, starting near the transducer and drawing the tissue across the optical surface toward the other end. Do not damage the bond wires! Do not reuse the tissue as the mounting silver epoxy may be spread onto the window of the crystal.
- Repeat with a new tissue each time and for each surface that needs cleaning.
- Replace the AOBD cover and screws.
- Realign the AOBDs in your system and adjust the Bragg angle for maximum diffraction efficiency.

#### Notes:

- The lens tissue must be lint free and the best grade available.
- Only use each tissue once, for only one surface. Do not reuse the tissue, as it will redistribute the removed dust or mounting silver epoxy.
- The acetone must be electronic grade. The acetone must be fresh from a new bottle, as the acetone will absorb water from the air and cause streaks. Discard any acetone, which has been exposed to the air for more than 4 hours. If the bottle is half- empty, do not use.