



NEOS TECHNOLOGIES

A Gooch & Housego Company

OPERATING MANUAL

TEN NANOSECOND AO MODULATOR

MODEL NUMBER:

15260

DOCUMENT NUMBER: 51A05436A

Document approved for release: W Seale Date: 6/06/06

US OFFICE: NEOS Technologies, Inc. ♦ 4005 Opportunity Drive ♦ Melbourne, FL 32934 ♦ USA

Tel: (321) 242-7818 ♦ Fax: (321) 242-1019 ♦ Email: neos@neostech.com

UK OFFICE: Gooch & Housego ♦ The Old Magistrates Court ♦ Ilminster, Somerset TA19 0AB ♦ UK

Tel: +44 1460 52271 ♦ Fax: +44 1460 54972 ♦ Email: sales@goochandhousego.com

TABLE OF CONTENTS

<u>SECTION</u>	<u>DESCRIPTION</u>	<u>PAGE</u>
I.	INSPECTION PROCEDURE	3
II.	DESCRIPTION	4
III.	SPECIFICATIONS	5
IV.	OUTLINE DRAWING	6
V.	CALCULATIONS	7
VI.	OPERATING PROCEDURE	8
VII.	CLEANING PROCEDURE	10

SECTION I
INSPECTION PROCEDURE

Examine the shipping carton for damage. If the shipping carton or packing material is damaged it should be kept for the carrier's inspection. Notify the carrier and NEOS Technologies. Check the contents of the shipment for completeness, mechanical damage, and then test the equipment electronically. Operating procedures are contained in Section VI. If the contents are incomplete, or the equipment does not pass the electrical testing please notify NEOS Technologies.

If there is any problem with the use of this equipment, or if the equipment fails to function as expected contact NEOS Technologies, do not try to trouble shoot or repair this equipment. Consult with a NEOS service engineer. If the equipment needs repair or replacement, contact NEOS Technologies, Inc for a Return Authorization Number.

SECTION II

DESCRIPTION

ACOUSTO-OPTIC MODULATOR

15260

The 15260 AO modulator consists of a Tellurium Dioxide crystal with a Lithium Niobate transducer. Optimum diffraction efficiency will be provided with a rise time of 10 nanoseconds correlating to a waist diameter in the TeO₂ crystal of 55 μ m. The modulator assembly should be mounted on a fixture to provide sufficient adjustment to peak the modulator efficiency (Bragg angle, horizontal, and vertical position) and the lens must be supplied to achieve the rise time. See section V for calculations. This modulator in the 15210-FOA package can be purchased with the 71002 optical mount with lenses.

The modulator can be driven with any good driver with a nominal 50 Ω output of 260 MHz, however, it is recommended that a NEOS driver be used to drive this modulator to achieve optimum performance. The RF input to the modulator should not exceed 1 watt CW. NEOS will not warranty any such damage resulting from too much RF power. Be extremely careful not to focus the laser beam on the gold bond wires on the acoustic transducer, which may vaporize the bond wires. NEOS will not warranty any such damage. The modulator has been designed and verified to satisfy the specifications.

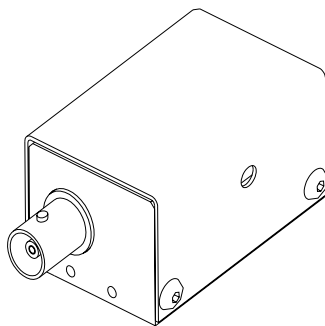

53B0504

15260

SECTION III**DEVICE SPECIFICATIONS**

15260

PARAMETER	SPECIFICATION
Interactive Material	TeO ₂
Acoustic Mode	Longitudinal
Operating Wavelength	440 – 850 nm
Window Configuration	AR Coated
Transmission	>95 %
Operating Frequency	260 MHz
Diffraction Efficiency	>70 % @ 633nm with Linear, Polarization Perpendicular to Acoustic Propagation or with Random Polarization
Acoustic Aperture Size	0.2 mm
Rise Time	<10 ns
Optical Waist Size to achieve Rise Time	55 μm
Deflection Angle	39 mrad @ 633 nm
RF Power Level	700 mW
Impedance	50 Ohms nominal
VSWR	1.5:1 @ 260MHz
Package:	53B0504
Acceptance Test Procedure:	42A12764
Acceptance Test Results Form:	52A00623
Recommended Drivers:	
Analog Driver System: 21260-1AS	Digital Driver System: 21260-1DS
Analog Driver Module: 21260-1AM	Digital Driver Module: 21260-1DM

SECTION IV
OUTLINE DRAWING

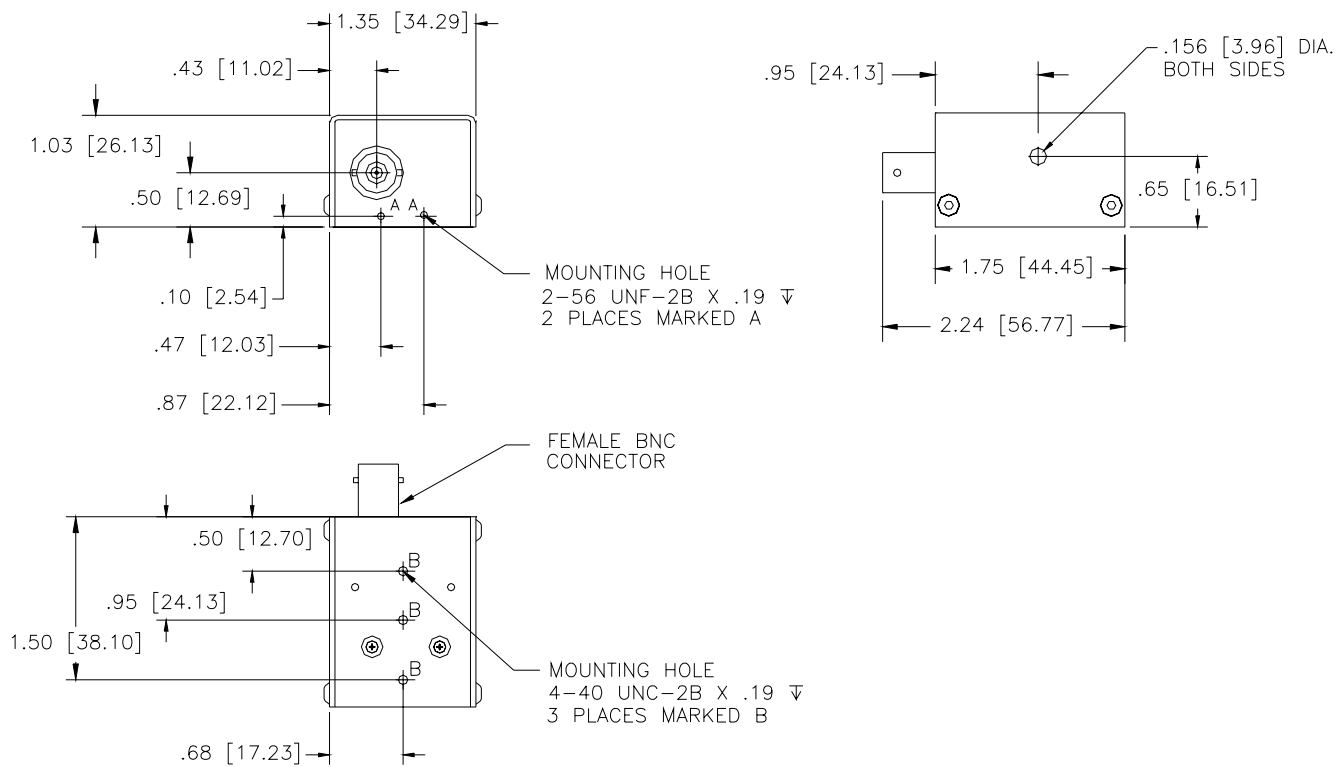

15260

53B00504

Dimensions are in inches

Tolerances: Decimal: .xx = .01 .xxx = .005

Dimensions in [] are in mm.

Millimeter: .xx = .25mm .xxx = .127mm

Angle: = ± 30'

SECTION V

CALCULATIONS

- The equations to determine the AOM rise time "t_r" are as follows:

First determine the waist size by the equation:
$$d_0 = \frac{4f\lambda}{\pi d_1}$$

Where: f = lens focal length in mm

λ = the optical wavelength in 10⁻⁶m

d₁ = the input optical beam diameter in mm

d₀ = the waist diameter inside the modulator in 10⁻⁶m

Knowing the waist size inside the modulator, then the modulator rise time can be calculated from the relationship:

$$t_r = \frac{1.3d_0}{2V}$$

Where: V = the acoustic velocity of the modulator material which is 4260 m/s

- The focal length of the lens is the F# of the lens times the input spot diameter:

$$F\# d_1 = f_{\text{lens}}$$

f_{lens} should be between 80 to 130 mm depending upon λ .

- The deflection angle " \varnothing_d " is defined as the acoustic drive frequency in megahertz times the wavelength, divided by the acoustic velocity of the material:

$$\varnothing_d = 2\theta_{\text{Bragg}} = \frac{f_a \lambda}{V} = \frac{260 \times 10^6 \lambda}{4260 \text{ m/s}}$$

Where: θ_{Bragg} = Bragg angle of the modulator.

SECTION IV**OPERATING PROCEDURE**

The optical alignment can be done as follows:

Mount the modulator in the optical path with the laser beam passing through the device window centered on the window vertically and close to the transducer (connector end). The modulator is polarization sensitive and performs best with light linear polarized, oriented perpendicular to the acoustic propagation axis. Random polarization can be used but the diffraction efficiency will be reduced by 10 %. The modulator mount assembly must have sufficient adjustments to peak the modulator efficiency (horizontal, vertical, and Bragg angle). Be extremely careful not to focus the laser beam on the gold bond wires on the acoustic transducer, which may vaporize the bond wires. NEOS will not warranty any such damage.

Using a 50 Ω coaxial cable, connect the "RF out" of the driver to the modulator. Turn on the RF power. Be sure the mode switch is in the CW position if using the NEOS driver system. Make sure that the RF power does not exceed 1 watt average power. NEOS will not warranty any failure resulting from the application of too much RF power.

With the laser beam going through the optical crystal, and close to the transducer, adjust the Bragg angle, by rotating the AOM, to allow the diffracted first order beam away from the transducer electrode (connector end) to be the most intense. See figure 3.

Install the lens, as calculated above, into the laser beam on the input side of the modulator to achieve the desired rise time. Position the lens 1 "f" away from the modulator and adjust the height of the modulator to achieve diffraction. Make changes in the Bragg adjustment screw to obtain optimum efficiency. Install a second lens 1 "f" away from the modulator on the output side to re-collimate the output beam. Make changes in the Bragg adjustment and height to obtain optimum efficiency. Adjust the RF driver for power level to obtain maximum diffraction efficiency.

For optimum results, the Bragg angle must be precisely adjusted. The angle between the reflected and the zero order beam is approximately equal to 0.039 radians at 633 nm, 0.031 radians at 514 nm, or 0.030 radians at 488 nm. The modulator has been designed and verified to satisfy the specifications.

To operate the modulator use the first order diffracted beam with the driver mode switch set to normal. See the driver manual for other information.

Figure 3

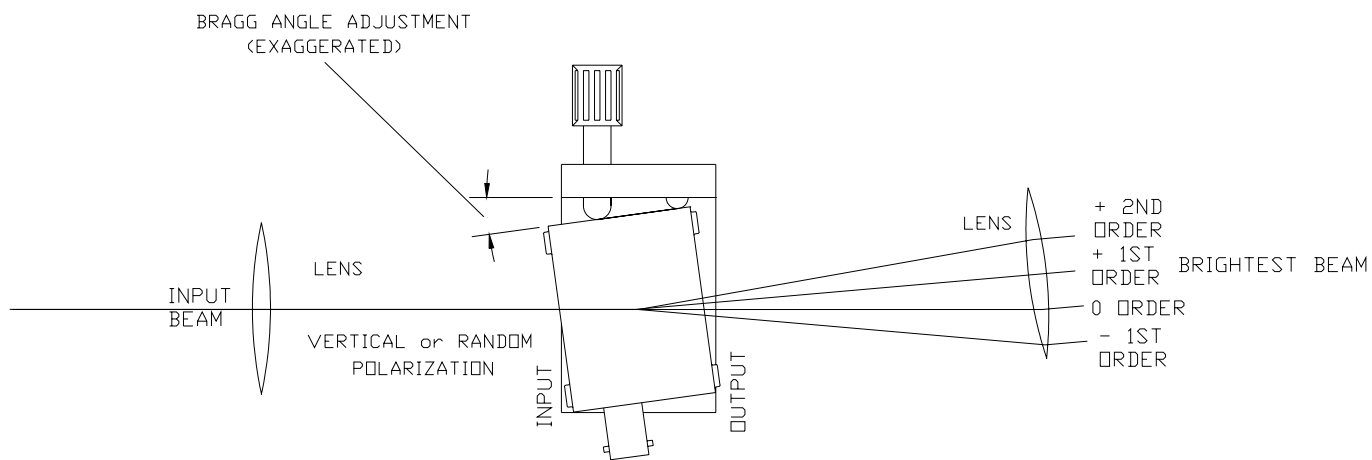

AOM Bragg adjustment

SECTION VII

OPTICAL CLEANING

Periodic cleaning of the AO device is a normal part of maintaining an optical system. When the device is installed in an optical system, make sure that there is access to allow removal of the protective cover and room to clean the device. If removal from the system is necessary, then follow the alignment procedure in this manual to reinstall, realign and, adjust the AO device.

To clean the AO device, remove the screws that hold the cover to the mount. **Caution** must be used when placing a screw driver near the window opening in the cover, as it is best to protect the opening with tape or cover the opening with your finger (without touching the crystal) to protect it. NEOS will not warrant any damage or scratches caused by inserting the screwdriver into the window opening.

- Remove the protective cover.
- Blow off any visible dust with canned air. Do not use an air gun unless it is filtered and water and oil free!
- Fold (4 times) a new lens tissue into a triangle to make a cleaning tool.
- Dip the tip of the lens tissue into **fresh** acetone or spray **fresh** acetone from a squeeze bottle onto it. Then shake excess fluid out of the lens tissue. Do not handle the wet area of the tissue, as your finger oil will be absorbed and contaminate the optical surface of the crystal.
- Wipe (only once) across the crystal in an even motion, starting near the transducer and drawing the tissue across the optical surface toward the other end. Do not damage the bond wires! Do not reuse the tissue as the mounting silver epoxy may be spread onto the window of the crystal.
- Repeat with a new tissue each time and for each surface that needs cleaning.
- Replace the protective cover and screws.
- Realign the device in your system and adjust the Bragg angle for maximum diffraction efficiency.

Notes:

- The lens tissue must be lint free and the best grade available.
- Only use each tissue once, for only one surface. Do not reuse the tissue, as it will redistribute the removed dust or mounting silver epoxy.
- The acetone must be electronic grade. The acetone must be fresh from a new bottle, as the acetone will absorb water from the air and cause streaks. Discard any acetone, which has been exposed to the air for more than 4 hours. If the bottle is half- empty, do not use.